

TRIUMPH

REPLACEMENT PARTS CATALOGUE No. 7

"C" RANGE MODELS
TWENTY-ONE (3TA)
SPEED TWIN (5TA)
TIGER 90 (T90)
TIGER 100 (T100)

from Engine No. H 40528

September 1965

TRIUMPH ENGINEERING COMPANY LIMITED
MERIDEN WORKS · ALLESLEY · COVENTRY · ENGLAND
TELEPHONE MERIDEN 331
TELEGRAMS "TRUSTY COVENTRY"

TRIUMPH GUARANTEE

1. In this Guarantee the word "machine" refers to the motor cycle, scooter, motor-cycle combination or sidecar as the case may be, purchased by the Purchaser.
2. In order to obtain the benefit of this Guarantee, the Purchaser must have correctly completed the registration form and returned it to us within fourteen days of the purchase.
3. We will supply, free of charge, a new part in exchange for, or, if we consider repair sufficient, will repair free of charge any part proved within six months of the date of purchase of any new machine, (3 months overseas) or within three months of its renewal or repair in the case of a part already renewed or repaired, to be defective by reason of our faulty workmanship or materials. We do not undertake to bear the cost of fitting such new or repaired part or accessory.
4. Any part considered to be defective must be sent to our Works, carriage paid, accompanied by the following information:—
 - (a) Name of purchaser and his address;
 - (b) Date of purchase of machine;
 - (c) Name of dealer from whom the purchase was made;
 - (d) Engine number and model
5. This Guarantee shall not extend to defect or damage appearing after misuse, neglect, abnormal stress or strain, or the incorporation or affixing of unsuitable attachments or parts and in particular:—
 - (a) Hiring out;
 - (b) Racing and Competitions;
 - (c) Adaptation or alteration of any part or parts after leaving our Works;
 - (d) The attaching of a sidecar in a manner not approved by us or to an unsuitable motor-cycle.

This Guarantee shall not extend to machines whose trade mark, name or manufacturing number has been altered or removed, or in which has been used any part not supplied or approved by us, or to tyres, saddles, chains, speedometers, revolution counters and electrical equipment or to parts supplied to the order of the Purchaser and different from our standard specification.

6. Our liability and that of our dealer who sells the machine, shall be limited to that set out in this guarantee, and no other claims for consequential damage or injury to person or property, shall be admissible. All other conditions and warranties statutory or otherwise and whether express or implied are hereby excluded and no guarantee other than that expressly herein contained applies to the machine to which this Guarantee relates or any accessory or part thereof.
7. We reserve the right to modify or deviate from the Published Specification without notice.

REPAIRS GUARANTEE

1. Whilst the highest standard of workmanship and materials is aimed at, we cannot accept liability for any defects appearing more than three months after the machine, assembly or component has left our Works after being repaired.
2. We will repair or replace at our option free of charge any defective work, materials or parts relating to the repairs carried out by us appearing within that time but shall not be under any further, or other liability for any other loss or damage whether direct or consequential and our liability shall be limited to the cost of so making good. We do not undertake to bear the cost of fitting any replacement or repaired part.
3. We do not accept liability in respect of parts of proprietary manufacture, e.g. tyres, saddles, chains speedometers, revolution counters and electrical equipment which may be used by us in effecting a repair. All other conditions and warranties statutory or otherwise express or implied are hereby excluded.

TRIUMPH SPARES

HOW TO ORDER. Every part is indicated by number, and this should be quoted together with the description. In order to assist customers, dimensions have been given in many cases where parts are similar. Parts where possible have been listed in order of assembly and a number of the illustrations show the assembly order also. With these aids there should be no difficulty in identifying the parts you require. **Always head your order with the engine number, stamped on the left side of the crank case underneath the cylinder flange, together with the prefix letters.**

WHERE TO OBTAIN. Triumph Spare Parts can only be obtained from an authorised Triumph Dealer, and we recommend our customers to place their orders with the Triumph Dealer in their district. When parts not usually asked for are required, and for which the Dealer may have to write or obtain specially, the postage or carriage incurred becomes payable.

Triumph Spares are not supplied to private owners direct from the factory. If difficulty is experienced in obtaining the required parts, the matter should be taken up directly with the Triumph Spares Department.

Customers are warned against the risk incurred by purchasing parts that are not of genuine Triumph manufacture. This risk is eliminated if parts are ordered as instructed from recognised Dealers.

PATTERNS AND PARTS FOR REPAIR. It is not necessary to send patterns if the part number is quoted. The sending of patterns often delays the order as parcel post or rail takes longer than letter post.

Parts sent to Coventry for repair, replacement, or as patterns should bear the sender's name and address and clear instructions should accompany the parts. In your own interest send a copy of the advice note under separate cover. All parts must be forwarded carriage paid and care should be taken to ensure that all remittances are sent separately and not enclosed with the parts. Fragile units such as cylinders, etc., should always be boxed to avoid damage in transit. Complete machines should have all fitments such as windscreens, driving mirrors, tools, etc., removed by the sender before despatch, as it is impossible for us to accept responsibility in the event of loss in transit. We are always pleased to give estimates for overhauling and repairs, but should an estimate not be accepted, a charge will be made covering cost of dismantling and re-assembling, if carried out.

Communications relating to Parts should be addressed to the SPARES DEPARTMENT and for repairs, guarantee claims and technical advice to the SERVICE DEPARTMENT, Triumph Engineering Co. Ltd., Meriden Works, Allesley, Coventry. In order to facilitate quick reference, the quoting of any number, invoice number or reference from previous communications is essential. Accessories not of our manufacture should be sent direct to the actual makers, whose names and addresses appear below.

PROPRIETARY GROUP

Ancillary equipment which is fitted to our motor cycles is of the highest quality and is guaranteed by the manufacturer and not by ourselves. Any repairs or claims should be made to the actual makers or their local agents who will always give owners every possible assistance. The following are the addresses of the various manufacturers:—

CARBURETTERS
Messrs. Amal Ltd.,
Holdford Rd., Witton, Birmingham 6.

SPARKING PLUGS
Champion Sparking Plug Co. Ltd.,
Feltham, Middlesex.

CHAINS
Renold Chains Ltd.,
Wythenshawe, Manchester.

SPEEDOMETERS
Messrs. Smiths Motor Accessories Ltd.,
Cricklewood Works, London, N.W.2.

ELECTRICAL EQUIPMENT
Messrs J. Lucas Ltd.,
Gt. Hampton St., Birmingham, 18.

SUSPENSION UNITS
Messrs. Girling Ltd.,
Birmingham Road, West Bromwich, Staffs.

TYRES
Dunlop Rubber Co. Ltd.,
Fort Dunlop,
Birmingham, 24.

ILLUSTRATION INDEX

<i>Fig. No.</i>	<i>Description</i>	<i>Page No.</i>
1	CRANKSHAFT AND CONNECTING RODS	16
2	CRANKCASE	18
3	OIL PUMP, RELEASE VALVE AND INLET MANIFOLD	20
4	CYLINDER BLOCK AND HEAD, 3TA AND T90	22, 24
5	CYLINDER BLOCK AND HEAD 5TA AND T100	26
6	TIMING COVER AND CONTACT BREAKER	28
7	GEARBOX SHAFTS, BEARINGS AND INNER COVER	30, 32
8	GEARBOX OUTER COVER AND LEVERS	34
9	CLUTCH	36
10	CHAINCASE AND CHAINS	38
11	ENGINE FITTINGS AND EXHAUST SYSTEM	40
12	EXHAUST PIPES, UNDERSHIELD AND FOOTPEGS (T100C)	42
13	FRAME	44
14	SWINGING FORK, SUSPENSION UNITS AND CHAINGUARD	46
15	TELESCOPIC FRONT FORK, 3TA AND 5TA	48
16	NACELLE, HEADLAMP AND SWITCHES	50
17	TELESCOPIC FRONT FORK, T90 AND T100	52
18	TELESCOPIC FRONT FORK, U.S.A. EASTERN T100C	54
19	FRONT WHEEL	56
20	REAR WHEEL	58
21	QUICKLY DETACHABLE REAR WHEEL (NOT U.S.A.)	60
22	MUDGUARDS (STANDARD)	62
23	FENDERS (U.S.A.)	64
24	PANELS AND TWINSEAT	66
25	PETROL (GAS) TANKS	68
26	OIL TANK	70
27	BATTERY, TOOLKIT AND AIR FILTER	72
28	HANDLEBARS AND CONTROL LEVERS	74
29	CONTROL CABLES	76
30	CARBURETTER, 3TA AND 5TA	78
31	CARBURETTER, T90 AND T100	80
32	A.C. MAGNETO IGNITION COILS, WIRING HARNESS AND DIRECT LIGHTING	82
33	D.C. IGNITION COILS, HORN, RECTIFIER AND ZENER DIODE	84
34	T90 AND T100 HEADLAMP, WIRING HARNESS, SWITCHES AND TAIL LAMP	86
35	SPEEDOMETER AND TACHOMETER	88

INDEX

	<i>Page</i>		<i>Page</i>
AIR FILTER ...	73	MANIFOLD ...	21
ALTERNATOR ...	17, 39	MUDGUARDS ...	63
BATTERY CARRIER ...	73	MUFFLERS ...	41
CARBURETTER ...	79, 81	NACELLE ...	51
CARTON PACKS ...	10	OIL PUMP ...	21
CENTRE STAND ...	45	OIL TANK ...	71
CHAINCASE ...	39	PETROL TANK ...	69
CHAINS ...	39	PILLION FOOTRESTS ...	45
CLUTCH ...	37	PISTONS ...	17
COIL ...	83, 85	PROP STAND ...	45
CONTACT BREAKER ...	29	Q.D. REAR WHEEL (NOT U.S.A.) ...	61
CONTROL CABLES ...	77	REAR PANELS ...	67
CONTROL LEVERS ...	75	REAR WHEEL ...	59
CRANKCASE ...	19	RECTIFIER ...	85
CRANKSHAFT ...	17	SILENCERS ...	41
CYLINDER HEAD ...	23, 25, 27	SPARK PLUGS ...	85
ENGINE PLATES ...	41	SPEEDOMETER ...	89
EXHAUST PIPES ...	41, 43	STEERING RACES ...	45
FENDERS ...	65	SUSPENSION UNITS ...	47
FOOTRESTS ...	43, 45	SWITCHES ...	51, 87
FRONT FORKS ...	49, 53, 55	TIMING GEARS ...	17
FRONT WHEEL ...	57	TOOLKIT ...	73
GAS TANK ...	69	TWINSEAT ...	67
GASKET SETS ...	11	VALVES ...	23, 25, 27
GEARBOX ...	31, 33, 35	WIRING HARNESS ...	51, 83, 85
HANDLEBARS ...	75		
HORN ...	83, 85		

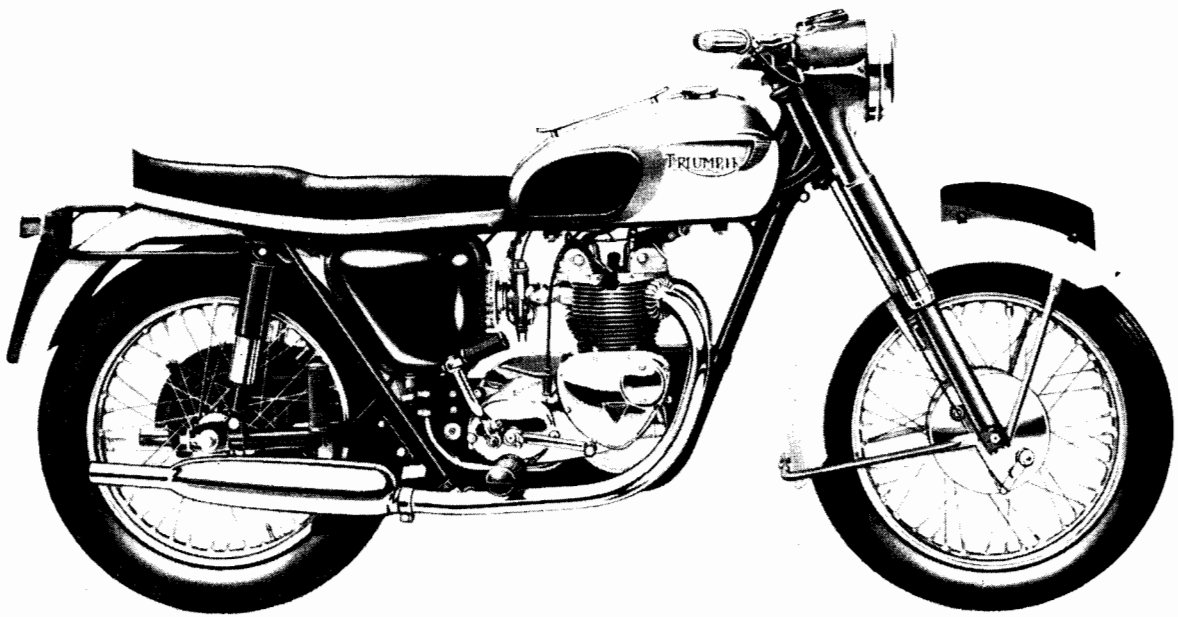

TWENTY-ONE (3TA) TECHNICAL DATA

Bore and stroke		58.25 x 65.5 mm. 2.292 in. x 2.578 ins.
Capacity		348 c.c. (21.23 cu. ins.).
Compression Ratio		7.5 : 1
Sparking Plugs		Champion N4
Carburetter		Amal Monobloc 375
	Main Jet	100
	Needle Jet	.106
	Needle	Type B
	Throttle Valve	375/3½
	Pilot Jet	25
Gearbox Sprocket		17 teeth
Chains	Front	$\frac{3}{8}$ in. Duplex x 78 links
	Rear	$\frac{5}{8}$ in. x $\frac{3}{8}$ in. x 102 links
Capacities	Fuel Tank	3½ galls. (16 litres)
	Oil Tank	6 pints (3.5 litres)
	Gearbox	2/3 pint (375 c.c.)
	Primary Chaincase	½ pint (300 c.c.)
	Front Forks (each leg)	$\frac{1}{8}$ pint (190 c.c.)
Brakes	Front and Rear, diameter	7 in. (17.78 cm.)
Tyre Size	Front	3.25 x 18
	Rear	3.50 x 18

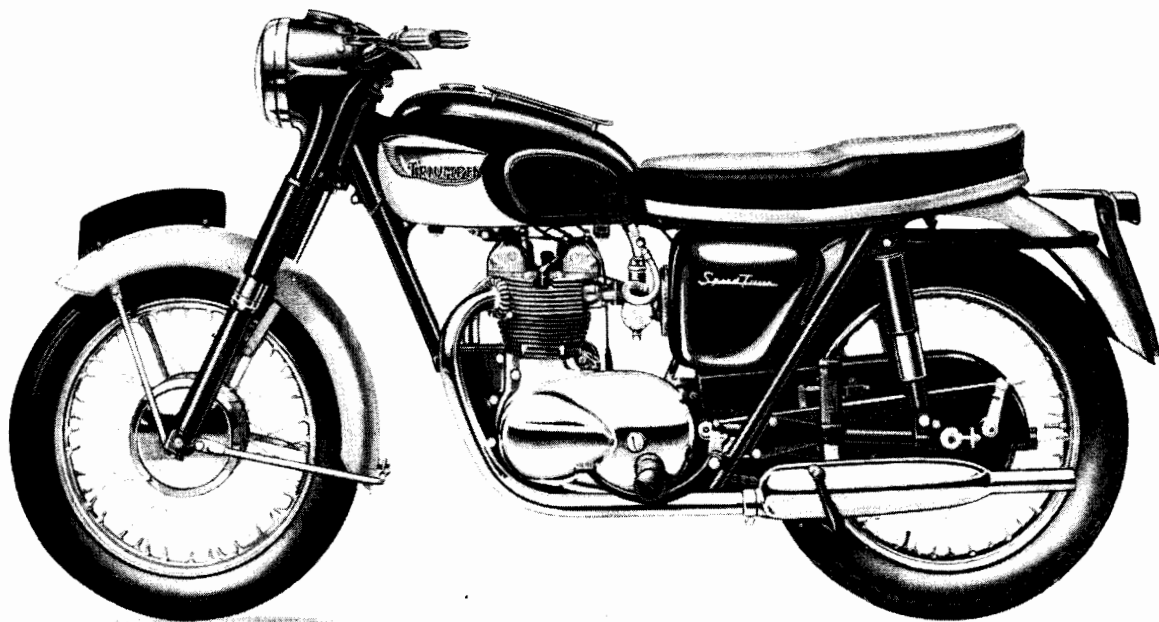

SPEED TWIN (STA) TECHNICAL DATA

Bore and Stroke		69 x 65.5 mm. 2.716 x 2.578 ins.
Capacity		490 c.c. (29.8 cu. ins.)
Compression Ratio		7 : 1
Sparking Plugs		Champion N4
Carburettor		Amal Monobloc 375
	Main Jet	160
	Needle Jet	.105
	Needle	Type B
	Throttle Valve	375/3
	Pilot Jet	25
Gearbox Sprocket		19 teeth
Chains	Front	$\frac{3}{8}$ in. Duplex x 78 links
	Rear	$\frac{5}{8}$ in. x $\frac{3}{8}$ in. x 103 links
Capacities	Fuel Tank	3½ galls. (16 litres)
	Oil Tank	6 pints (3.5 litres)
	Gearbox	2/3 pint (375 c.c.)
	Primary Chaincase	½ pint (300 c.c.)
	Front Forks (each leg)	$\frac{1}{8}$ pint (190 c.c.)
Brakes	Front and Rear, diameter	7 in. (17.78 cm.)
Tyre Size	Front	3.25 x 18
	Rear	3.50 x 18

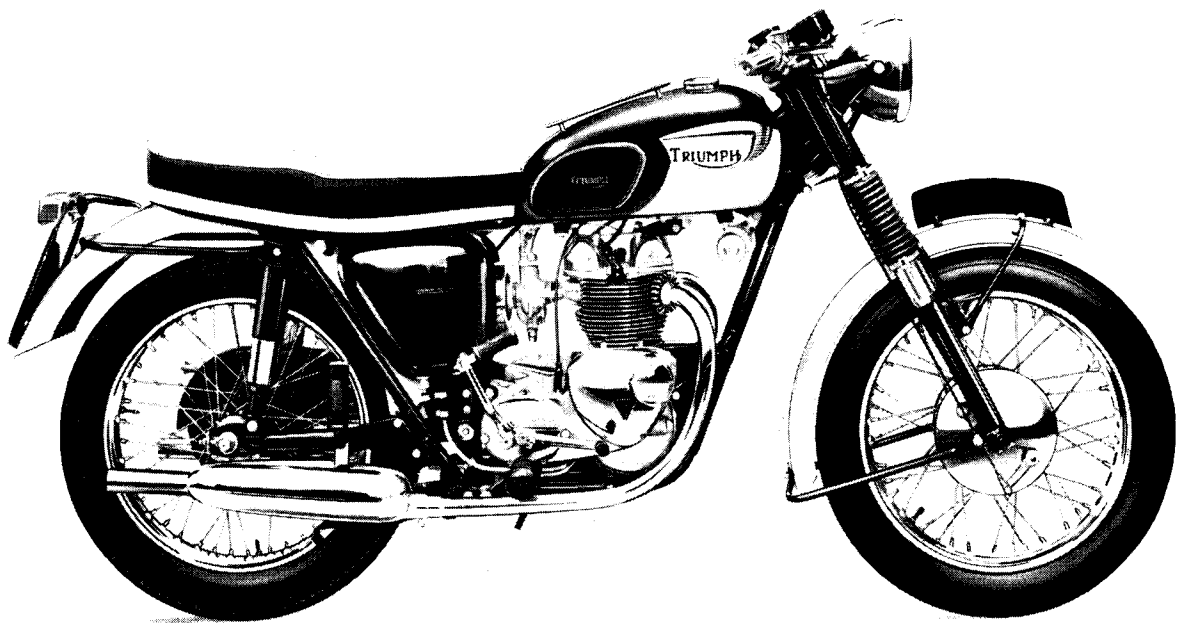

TIGER 90 (T90) TECHNICAL DATA

Bore and Stroke		58.25 x 65.5 mm. 2.292 x 2.578 ins.
Capacity		348 c.c. (21.23 cu. ins.)
Compression Ratio		9 : 1
Sparking Plugs		Champion N4
Carburetter		Amal Monobloc
	Main Jet	180
	Needle Jet	.106
	Needle	Type C
	Throttle Valve	376/31 $\frac{1}{2}$
	Pilot Jet	20
Gearbox Sprocket		17 teeth
Chains	Front	$\frac{3}{8}$ in. Duplex x 78 links
	Rear	$\frac{5}{8}$ in. x $\frac{3}{8}$ in. x 102 links
Capacities	Fuel Tank	3 $\frac{1}{2}$ galls. (16 litres)
	Oil Tank	6 pints (3.5 litres)
	Gearbox	2/3 pint (375 c.c.)
	Primary Chaincase	$\frac{1}{2}$ pint (300 c.c.)
	Front Forks (each leg)	$\frac{1}{3}$ pint (190 c.c.)
Brakes	Front and Rear, diameter	7 in. (17.78 cm.)
Tyre Size	Front	3.25 x 18
	Rear	3.50 x 18

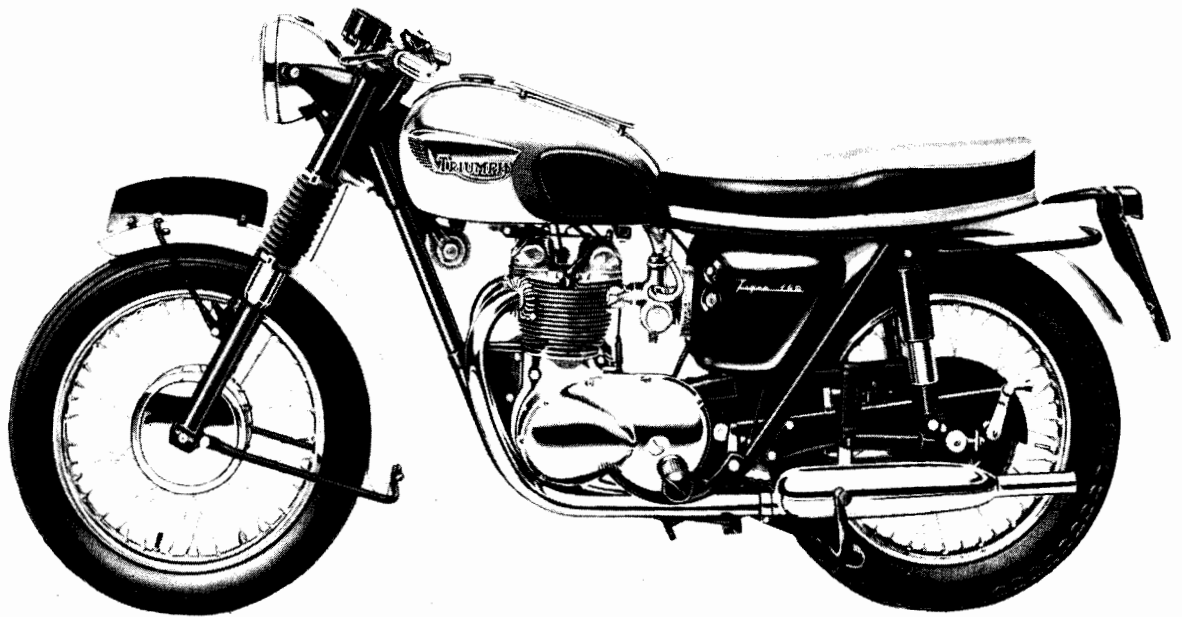

TIGER 100 (T100) TECHNICAL DATA

Bore and Stroke		69 x 65.5 mm. 2.716 x 2.578 ins.
Capacity		490 c.c. (29.8 cu. ins.)
Compression Ratio		9 : 1
Sparking Plugs		Champion N4
Carburetter		Amal Monobloc
	Main Jet	190
	Needle Jet	.106
	Needle	Type C
	Throttle Valve	376/3½
	Pilot Jet	25
Gearbox Sprocket		18 teeth
Chains	Front	¾ in. Duplex x 78 links
	Rear	¾ in. x ¾ in. x 102 links
Capacities	Fuel Tank	3½ galls. (16 litres)
	Oil Tank	6 pints (3.5 litres)
	Gearbox	2/3 pint (375 c.c.)
	Primary Chaincase	½ pint (300 c.c.)
	Front Forks (each leg)	⅓ pint (190 c.c.)
Brakes	Front and Rear, diameter	7 in. (17.18 cm.)
Tyre Size	Front	3.25 x 18
	Rear	3.50 x 18

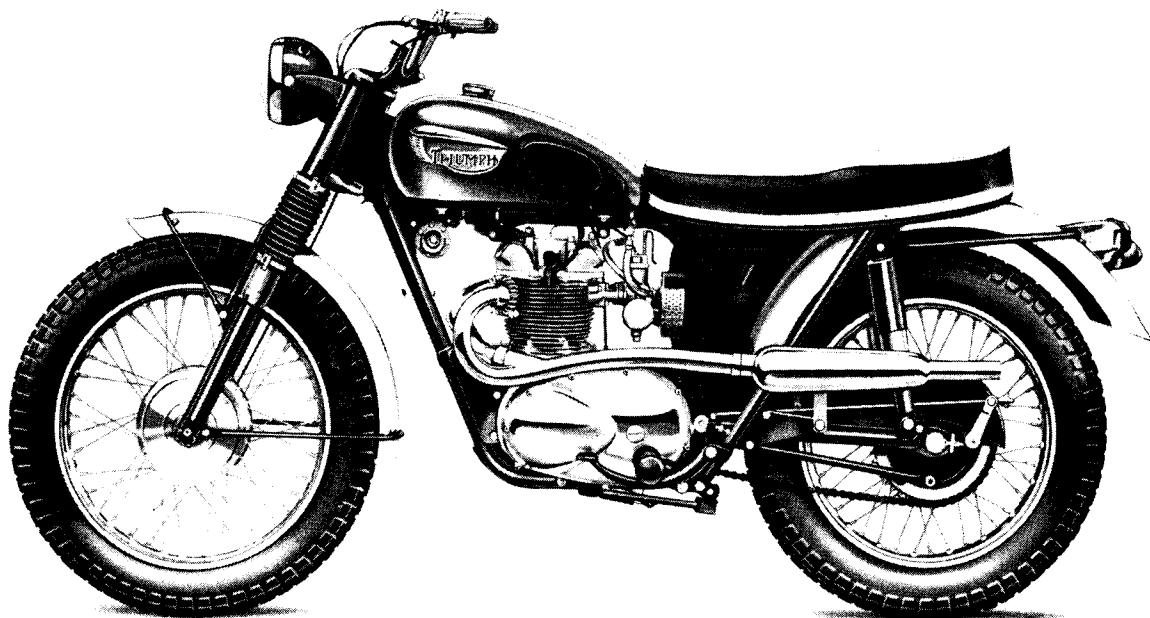

U.S.A. TIGER 100 (EASTERN T100C) TECHNICAL DATA

Bore and Stroke		2.716 x 2.578 ins.
Capacity		29.8 cu. ins.
Compression Ratio		9 : 1
Sparking Plugs		Champion N4
Carburetter		Amal Monobloc
	Main Jet	190
	Needle Jet	.106
	Needle	Type C
	Throttle Valve	37 $\frac{6}{8}$ / $\frac{3}{2}$
	Pilot Jet	25
Gearbox Sprocket		18 teeth
Chains	Front	$\frac{3}{8}$ in. Duplex x 78 links
	Rear	$\frac{5}{8}$ in. x $\frac{3}{8}$ in. x 102 links
Capacities	Gas Tank	2 $\frac{3}{8}$ U.S. galls.
	Oil Tank	6 U.S. pints
	Gearbox	$\frac{2}{3}$ pint (375 c.c.)
	Primary Chaincase	$\frac{1}{2}$ pint (300 c.c.)
	Front Forks (each leg)	$\frac{1}{3}$ pint (190 c.c.)
Brakes	Front and Rear, diameter	7 in. (17.18 cm.)
Tyre Size	Front	3.25 x 19
	Rear	4.00 x 18

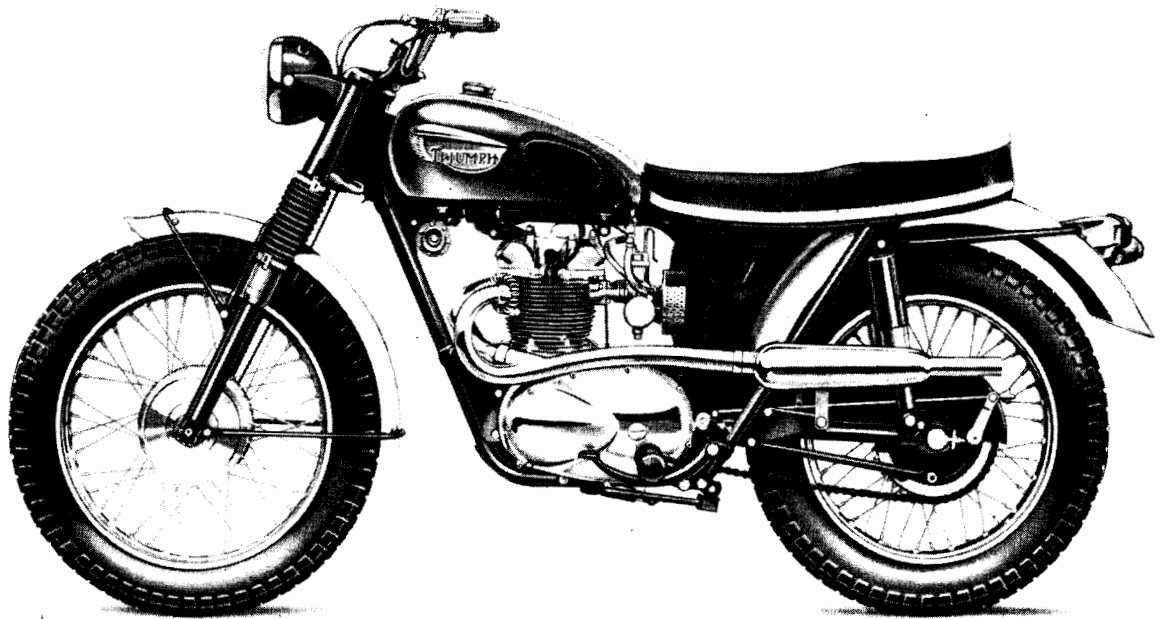

U.S.A. TIGER 100 (WESTERN T100C) TECHNICAL DATA

Bore and Stroke		2.716 x 2.578 ins.
Capacity		29.8 cu. ins.
Compression Ratio		9 : 1
Sparking Plugs		Champion N4
Carburetter		Amal Monobloc
	Main Jet	190
	Needle Jet	.106
	Needle	Type C
	Throttle Valve	$37\frac{6}{32}$
	Pilot Jet	25
Gearbox Sprocket		18 teeth
Chains	Front	$\frac{3}{8}$ in. Duplex x 78 links
	Rear	$\frac{5}{8}$ in. x $\frac{3}{8}$ in. x 102 links
Capacities	Gas Tank	$2\frac{3}{8}$ U.S. galls.
	Oil Tank	6 U.S. pints
	Gearbox	$\frac{2}{3}$ pint (375 c.c.)
	Primary Chaincase	$\frac{1}{2}$ pint (300 c.c.)
	Front Forks (each leg)	$\frac{1}{3}$ pint (190 c.c.)
Brakes	Front and Rear, diameter	7 in. (17.18 cm.)
Tyre Size	Front	3.25 x 19
	Rear	4.00 x 18

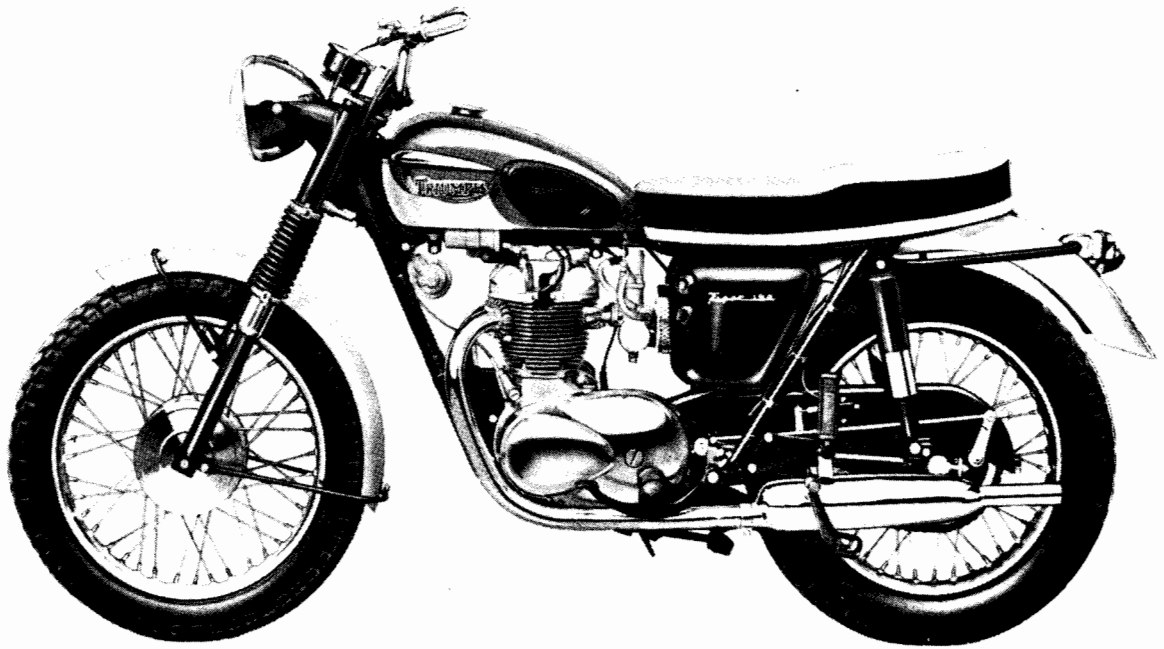

U.S.A. TIGER 100 (T100R) TECHNICAL DATA

Bore and Stroke		2.716 x 2.578 ins.
Capacity		29.8 cu. ins.
Compression Ratio		9 : 1
Sparking Plugs		Champion N4
Carburetter		Amal Monobloc
	Main Jet	190
	Needle Jet	.106
	Needle	Type C
	Throttle Valve	376/3½
	Pilot Jet	25
Gearbox Sprocket		19 teeth
Chains	Front	¾ in. Duplex x 78 links
	Rear	⅝ in. x ⅝ in. x 102 links
Capacities	Gas Tank	2¾ U.S. Galls.
	Oil Tank	6 U.S. pints
	Gearbox	2/3 pint (375 c.c.)
	Primary Chaincase	½ pint (300 c.c.)
	Front Forks (each leg)	⅜ pint (190 c.c.)
Brakes	Front and Rear, diameter	7 in. (17.18 cm.)
Tyre Size	Front	3.25 x 19
	Rear	4.00 x 18

HOW TO USE THIS PARTS CATALOGUE

First check that the engine number of your machine is subsequent to that quoted on the title page.

Next consult the index on Page 5 for the parts or group of parts which you wish to locate. When you have located the parts make sure from the end columns that the part you have located does apply to your machine.

List the quantities required as single units: do not ask for "2 pairs" or "3 dozen".

In case of painted items always state the colour required. Painted parts are available only in the colours or alternatives specified for that model of that particular year.

<i>Model</i>	<i>Colour</i>	<i>Suffix Letter to Part No.</i>
3TA	PACIFIC BLUE/ALASKAN WHITE	PB/AW
5TA	BLACK/SILVER	W/V
T90	GRENADIER RED/ALASKAN WHITE	GR/AW
T100	SHERBOURNE GREEN/ALASKAN WHITE	SG/AW

N.B. Pacific Blue is a flamboyant finish applied over Silver Sheen.

Paint is available also in all colours in $\frac{1}{4}$ pint or 1 gallon tins, or Aerosol containers.

PLEASE NOTE

THROUGHOUT THIS LIST, ASSEMBLIES ARE PRINTED IN CAPITALS AND THE COMPONENTS INCLUDED IN THAT ASSEMBLY ARE INDENTED IN THE DESCRIPTION COLUMN, REVERTING TO THE ORIGINAL ALIGNMENT WHEN THE ASSEMBLY IS COMPLETE. TO ORDER THE COMPLETE ASSEMBLY IT IS NECESSARY ONLY TO QUOTE THE ASSEMBLY NUMBER. ANY COMPONENT PARTS LISTED MAY ALSO BE OBTAINED SEPARATELY IF REQUIRED.

SPECIAL WORKSHOP TOOLS

A COMPLETE LIST OF WORKSHOP TOOLS CAN BE MADE AVAILABLE BY EITHER CONTACTING YOUR DEALER OR APPLYING DIRECT TO THE TRIUMPH SERVICE DEPARTMENT. IN MOST CASES THESE TOOLS ARE VERY COSTLY AS THEY ARE MADE ENTIRELY FOR WORKSHOP USE, AND THEREFORE, IT IS NOT RECOMMENDED THAT THE PRIVATE OWNER PURCHASES THE TOOLS IN ORDER TO AID SERVICING THE MACHINE ONCE OR TWICE ONLY. IN THESE CIRCUMSTANCES IT IS FAR MORE ECONOMICAL TO GET IN TOUCH WITH A RECOGNISED DEALER.

CARTON PACK LIST

The following sub-assemblies are supplied in carton packs under the C.P. part number stated. The contents of these carton packs are preserved and will not deteriorate under adverse conditions.

Part No.	Contents	
Brake Lining		
C.P. 38/AM2	2 NW243	Brake Lining
	16 W129	Rivet
Steering Races		
C.P. 167	1 H1110	Cone
	1 H1140	Cone and dust cover
	2 H1130	Cup
	48 S70-4	Steel balls (3/16 in. diam.)
Pistons (350 c.c.)		
C.P. 164	1 E3689	Piston C.R. 7.5 : 1
	1 E3691	Compression ring (plain)
	1 E3690	Compression ring (taper)
	1 E3692	Oil control ring
	1 E1750	Gudgeon pin
	2 E1767	Circlips
C.P. 164 is also available in 0.010 in., 0.020 in. and 0.040 in. oversizes.		
C.P. 198	1 E4670	Piston C.R. 9 : 1
	2 E3690	Compression ring (taper)
	1 E3692	Oil control ring
	1 E1750	Gudgeon pin
	2 E1767	Circlips
C.P. 198 is also available in 0.010 in., 0.020 in. and 0.040 in. oversizes.		
Piston Rings (350 c.c.)		
C.P. 165	2 E3691	Compression ring (plain)
	2 E3690	Compression ring (taper)
	2 E3692	Oil control ring
C.P. 165 is also available in 0.010 in., 0.020 in. and 0.040 in. oversizes.		
Pistons (500 c.c.)		
C.P. 174	1 E4004	Piston C.R. 7 : 1
	2 E3829	Compression ring (taper)
	1 E3831	Oil control ring
	1 WE203E	Gudgeon pin
	2 WE479	Circlips
*C.P. 174 is also available in 0.010 in. and 0.020 in. oversizes.		
C.P. 179	1 E4021	Piston C.R. 9 : 1
	2 E3829	Compression ring (taper)
	1 E3831	Oil control ring
	1 WE203E	Gudgeon pin
	2 WE479	Circlips
C.P. 179 is also available in 0.010 in. and 0.020 in. oversizes.		
Piston Rings (500 c.c.)		
C.P. 175	4 E3829	Compression ring (taper)
	2 E3831	Oil control ring
C.P. 175 is also available in 0.010 in. and 0.020 in. oversizes.		

CARTON PACK LIST—continued

<i>Part No.</i>	<i>Contents</i>
-----------------	-----------------

C.P. 180	4 E4135 2 E4136	Compression ring (taper) Oil control rings
----------	--------------------	---

C.P. 180 can only be fitted to E4021 Piston body, and should only be used for high-performance work.

Valve Guides (3TA, 5TA)

C.P. 170	4 E3208	Valve guides
	4 E3209	Valve guides circlip

Valves (3TA)

C.P. 166	2 E3738	Inlet valve
	2 E3739	Exhaust valve

Valves (500 c.c.)

C.P. 176	2 E4012	Inlet valve
	2 E4013	Exhaust valve

Valve Springs

C.P. 177	4 E5946	Inner valve spring
	4 E4011	Outer valve spring

De-coke Gasket Set	All models	D/GS 6
--------------------	------------	--------

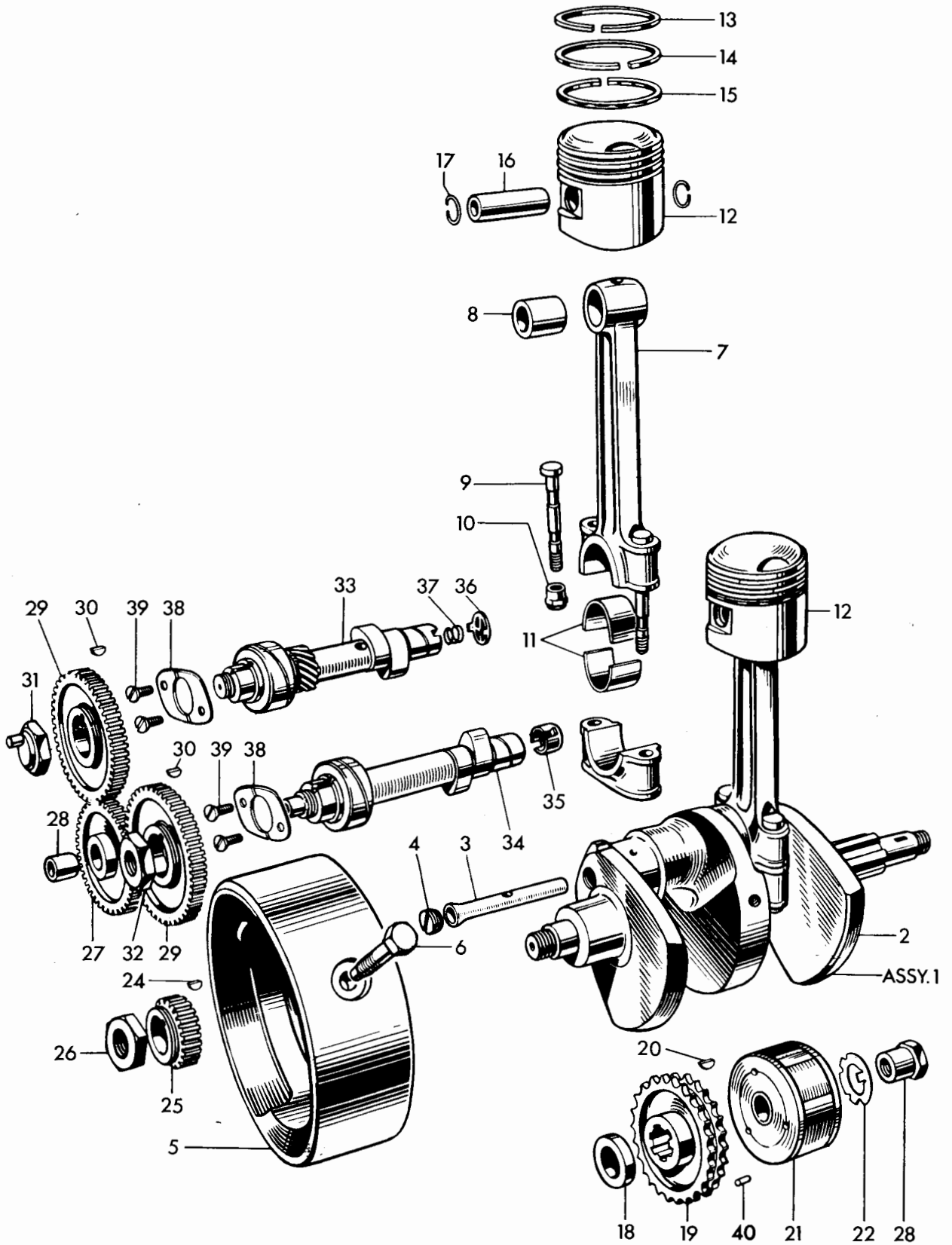

Fig. 1. CRANKSHAFT AND CONNECTING RODS

CRANKSHAFT AND CONNECTING RODS

Ref. No.	Part No.	Description	Quantity	Remarks
1	E5869	CRANKSHAFT AND FLYWHEEL ASSEMBLY	1	
2	E3998	Crankshaft	1	
3	E3999	Oil tube	1	
4	E3711	Screwed plug	1	
5	E5870	Flywheel	1	
6	*E3713	Flywheel bolt	3	
7	E3702	CONNECTING ROD	2	3TA, T90
7	E4001T	CONNECTING ROD...	2	5TA, T100
8	E1762	Small end bush	2	3TA, T90
8	E4003	Small end bush	2	5TA, T100
9	E3705	Connecting rod bolt	2	
10	E2922	Self-locking nut	2	
11	E3706	Big end bearing	4	
12	CP 164	PISTON COMPLETE C.R. 7.5:1	2	3TA
12	CP 174	PISTON COMPLETE C.R. 7:1	2	5TA
12	CP 198	PISTON COMPLETE C.R. 9:1	2	T90
12	CP 179	PISTON COMPLETE C.R. 9:1	2	T100
13	E3691	Plain compression ring	2	3TA
13	E3829	Taper compression ring	2	5TA, T100
14	E3690	Taper compression ring	2	3TA, T90 (4 ₁ off)
14	E3829	Taper compression ring	2	5TA, T100
15	E3692	Oil control ring	2	3TA, T90
15	E3831	Oil control ring	2	5TA, T100
16	E1750	Gudgeon pin	2	3TA, T90
16	WE 203E	Gudgeon pin	2	5TA, T100
17	E1767	Circlip	4	3TA, T90
17	WE 479	Circlip	4	5TA, T100
18	E4006	Distance collar	1	
19	E4141	Engine sprocket, 26T Duplex	1	
20	E3851	Rotor key	1	
21	54213901	Rotor, type RM 19	1	
21	54215824	Rotor, type RM19...	1	A.C. ignition
22	E3975	Tab washer	1	
23	E3735	Nut	1	
24	E1580	Key	1	
25	E1771	Timing pinion	1	
26	E398	Nut	1	
27	E6160	INTERMEDIATE WHEEL	1	
28	E400	Bush	1	
29	E1486A	Camshaft wheel...	2	
30	E1558	Camshaft key	2	
31	E1463	Inlet camshaft nut	1	
32	E4563	Exhaust camshaft nut	1	
33	E6120	Inlet camshaft	1	3TA. (Use E3838)
33	E4678	Inlet camshaft	1	5TA, T90, T100
34	E5341	Exhaust camshaft	1	3TA
34	E4786	EXHAUST CAMSHAFT	1	5TA, T90, T100
35	E4700	Tachometer drive thimble	1	
36	E5316	Rotary breather valve	1	
37	E2256	Breather valve spring	1	
38	E3727	Retaining plate	2	
39	E3728	Screw (15/32 in. U.H.)	4	
40	E4142	Dowel	1	A.C. ignition

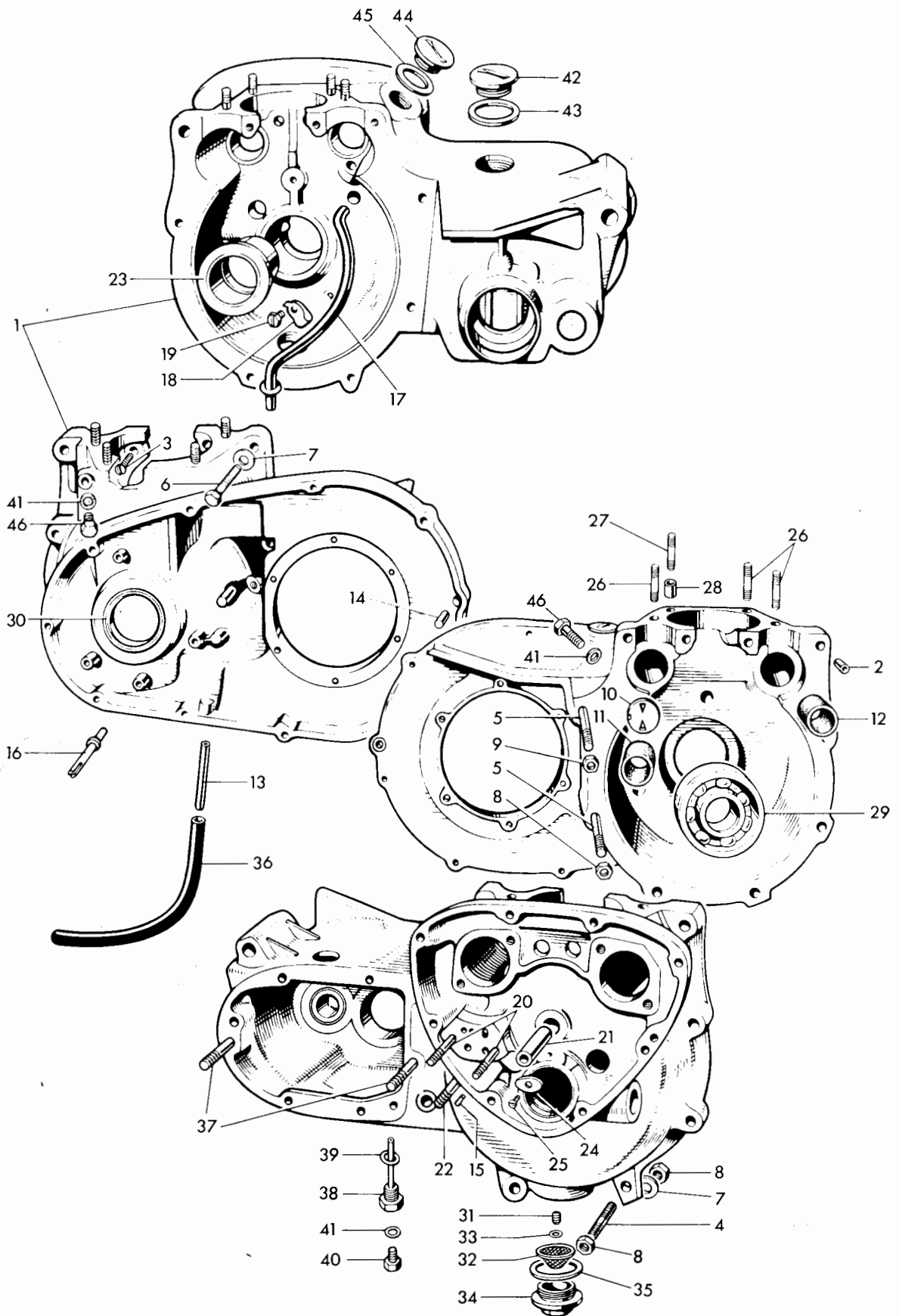

Fig. 2. CRANKCASE

CRANKCASE

Ref. No.	Part No.	DESCRIPTION	QUANTITY	REMARKS
1	E5868/4645	CRANKCASE c/w STUDS AND RIGHT MAIN BEARING	1	
2	E3716	Hollow dowel	1	
3	E3859	Screw (21/32 in. U.H.)	2	
4	E3804	Stud (3 in. O.A.)	1	
5	E3803	Stud (3 $\frac{3}{4}$ in. U.H.)	2	
6	E3799	Bolt (1 $\frac{5}{8}$ in. U.H.)	1	
7	S25-3	Plain washer	3	
8	S1-51	Nut	3	
9	E1310	Nut	1	
10	E3822	Breather disc	1	
11	E3824	Inlet camshaft bush	1	
12	E3823	Exhaust camshaft bush	1	
13	E2724	Breather pipe	1	
14	E6076	Blanking plug	1	Not serviced
15	E6386	Dowel	1	Not serviced
16	E4147	Chain tensioner abutment	1	
17	E3719	Oil scavenge pipe	1	
18	E1509	Clip	1	
19	E1645	Screw (17/64 in. U.H.)	1	
20	E3718	Oil pump stud (1 $\frac{5}{16}$ in. O.A.)	2	
21	E375	Intermediate wheel spindle	1	
22	E3717	Oil pipes stud (1 $\frac{1}{2}$ in. O.A.)	1	
23	E4322	Right main bearing	1	
24	E4139	Locating plate	1	
25	E4140	Self-tapping screw	1	
26	E3820	Cylinder stud (1 $\frac{1}{2}$ in. O.A.)	6	
27	E3819	Cylinder stud (1 $\frac{1}{4}$ in. O.A.)	2	
28	E1534A	Dowel	2	
29	E3835	Left main bearing (Ball-journal)	1	
30	E3876	Oil seal	1	
31	E3724	Filter spring	1	
32	E3722	Filter	1	
33	E3723	Sealing washer	1	
34	E1564	Filter cap	1	
35	E1577	Joint washer	1	
36	E3078	Breather extension rubber pipe	1	
37	T1399	Stud (3 $\frac{1}{4}$ in. O.A.)	2	
38	T1112	Drain plug (with level tube)	1	
39	WE 170	Fibre washer	1	
40	T361	Level plug	1	
41	T1257	Fibre washer	3	
42	E732	Filler plug	2	
43	NE507	Fibre washer	2	
44	E4587	Distributor hole plug	1	
45	E4593	Fibre washer	1	
46	E4706	Tachometer drive plug	2	

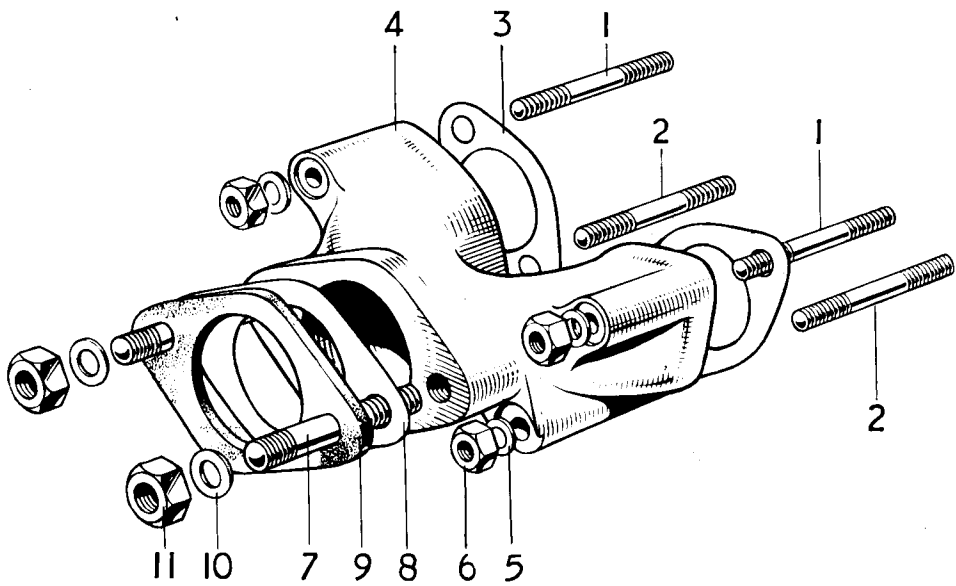
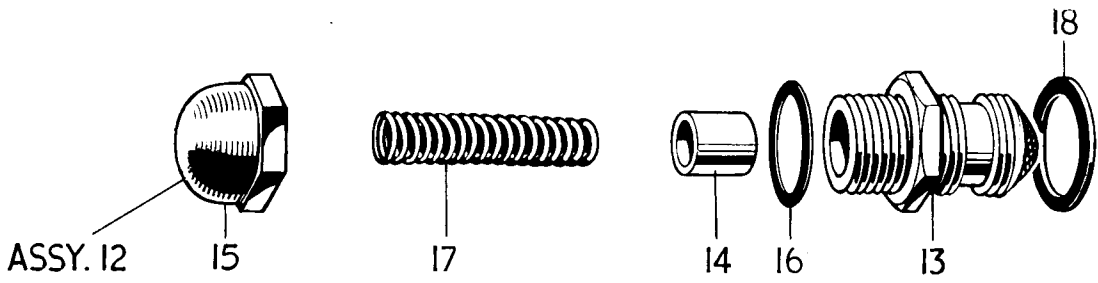
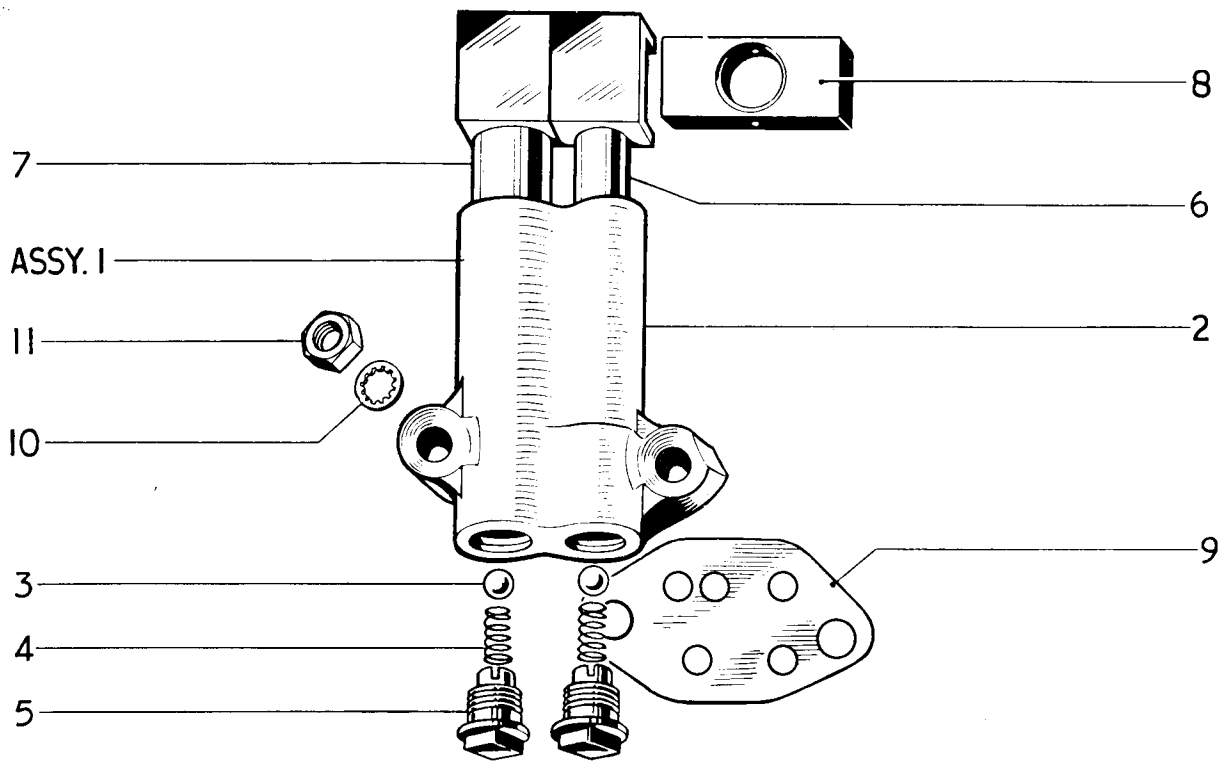

Fig. 3. OIL PUMP, RELEASE VALVE AND INLET MANIFOLD

OIL PUMP AND RELEASE VALVE

1	E3878	OIL PUMP	1	
2	E3731	Pump body...	1	
3	S70-7	Valve ball	2	
4	E403	Valve spring	2	
5	E2360	Screwed plug	2	
6	GS153	Feed plunger	1	
7	E1476	Scavenge plunger	1	
8	E495	Drive block	1	
9	E3730	Joint washer	1	
10	E3887	Serrated washer	2	
11	E3732	Nut	2	
12	E5896	OIL RELEASE VALVE	1	
13	E2794	Valve body	1	
14	GS251	Piston	1	
15	E2304	Cap	1	
16	GS254	Fibre washer	1	
17	E6062	Main spring	1	
18	E1670	Fibre washer	1	

INLET MANIFOLD

1	E3796	Stud (1 17/32 in. O.A.)	2	
2	E3797	Stud (2 in. O.A.)	2	
3	E2967	Joint washer	2	
4	E3761	Inlet manifold	1	3TA
4	E4014	Inlet manifold	1	5TA, T100
4	E4689	Inlet manifold	1	T90
5	S25-13	Plain washer	4	
6	W103	Nut	4	
7	E3880	Stud (1 1/4 in. O.A.)	2	
8	NA 43	Joint washer	1	3TA, 5TA
8	NA 43A	Joint washer	1	T90, T100
9	E3834	Insulating block	1	3TA, 5TA
9	E4504	Insulating block	1	T90
9	E2968	Insulating block	1	T100
10	S25-3	Plain washer	2	
11	S1-51	Nut	2	

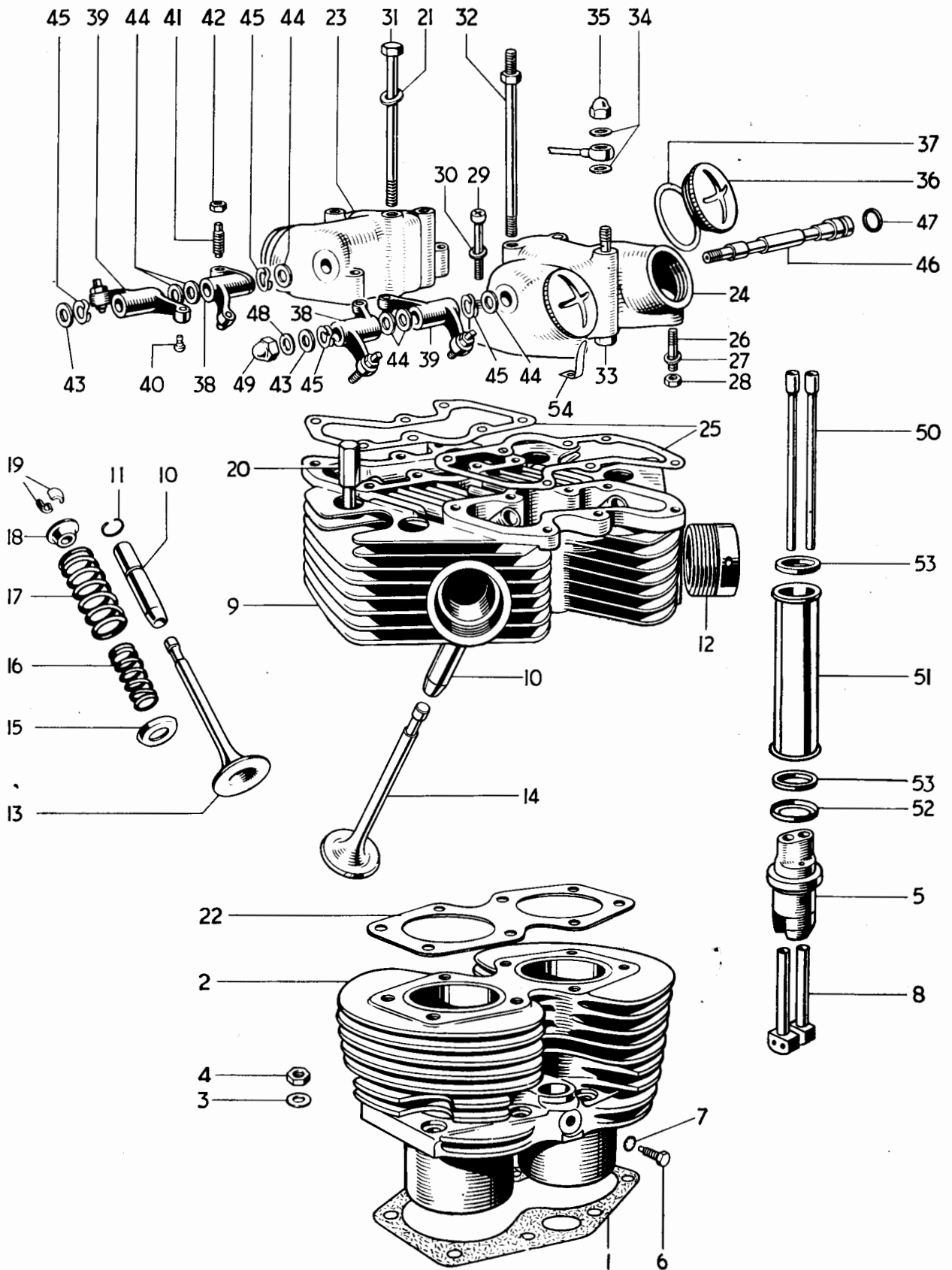

Fig. 4. CYLINDER BLOCK AND HEAD, 3TA AND T90

CYLINDER BLOCK AND HEAD, 3TA AND T90

1	E3798	Cylinder base washer	1	
2	E3698	Cylinder block	1	
3	GS308	Plain washer	8	
4	E2412	Nut	8	
5	E4676	Tappet guide block	2	
6	H200	Tappet block screw ($\frac{7}{16}$ in. U.H.)	2	
7	E1612	Serrated washer	2	
8	E3753	Tappet	4	
9	E5956	CYLINDER HEAD c/w GUIDES	1	3TA
9	E4784	CYLINDER HEAD c/w GUIDES	1	T90
10	E3208	Valve guide \emptyset	4	3TA
10	E6301	Valve guide	4	T90
11	E3209	Valve guide circlip	4	
12	E2961	Exhaust pipe adaptor	2	
13	E3738	Inlet valve	2	3TA
13	E4640	Inlet valve	2	T90
14	E3739	Exhaust valve	2	
15	E3740	Bottom cup	4	
16	E5946	Inner valve spring	4	
17	E4011	Outer valve spring	4	
18	E3742	Top collar	4	
19	WE259A	Split cotter	8	
20	E4456	Cylinder head bolt (2 $\frac{25}{32}$ in. U.H.)	4	
21	F2184	Plain washer	8	
22	E4674	Cylinder head gasket	1	
23	E3745	Inlet rocker box	1	
24	E3744	Exhaust rocker box	1	
25	E3743	Joint washer	2	
26	E3858	Rocker box stud ($\frac{1}{8}$ in. O.A.)	4	
27	E3302	Plain washer	4	
28	F879	Nut	4	
29	E3668	Screw ($\frac{1}{2}$ in. U.H.)	4	
30	E3857	Plain washer	4	
31	E3794	Cylinder head bolt (5 $\frac{7}{16}$ in. U.H.)	2	
32	E3795	Cylinder head torque stay bolt	2	
33	E3809	Oil feed bolt	2	
34	F1880	Copper washer	6	
35	H400	Domed nut	2	
36	E4610	Inspection cap	4	
37	E3751	Fibre washer	4	
38	E3749	ROCKER (Right exhaust, left inlet)	2	
39	E3750	ROCKER (Left exhaust, right inlet)	2	
40	E3222	Rocker ball pin	4	
41	E3223	Rocker adjusting pin	4	
42	GS662	Adjuster lock nut	4	
43	E1330	Thrust washer, $\frac{3}{8}$ in.	2	
44	E2534	Thrust washer, $\frac{7}{16}$ in.	6	
45	E3224	Spring washer	4	
46	E3748	Rocker spindle	2	
47	E3253	Sealing rubber	2	
48	E1335	Copper washer	2	

(Continued)

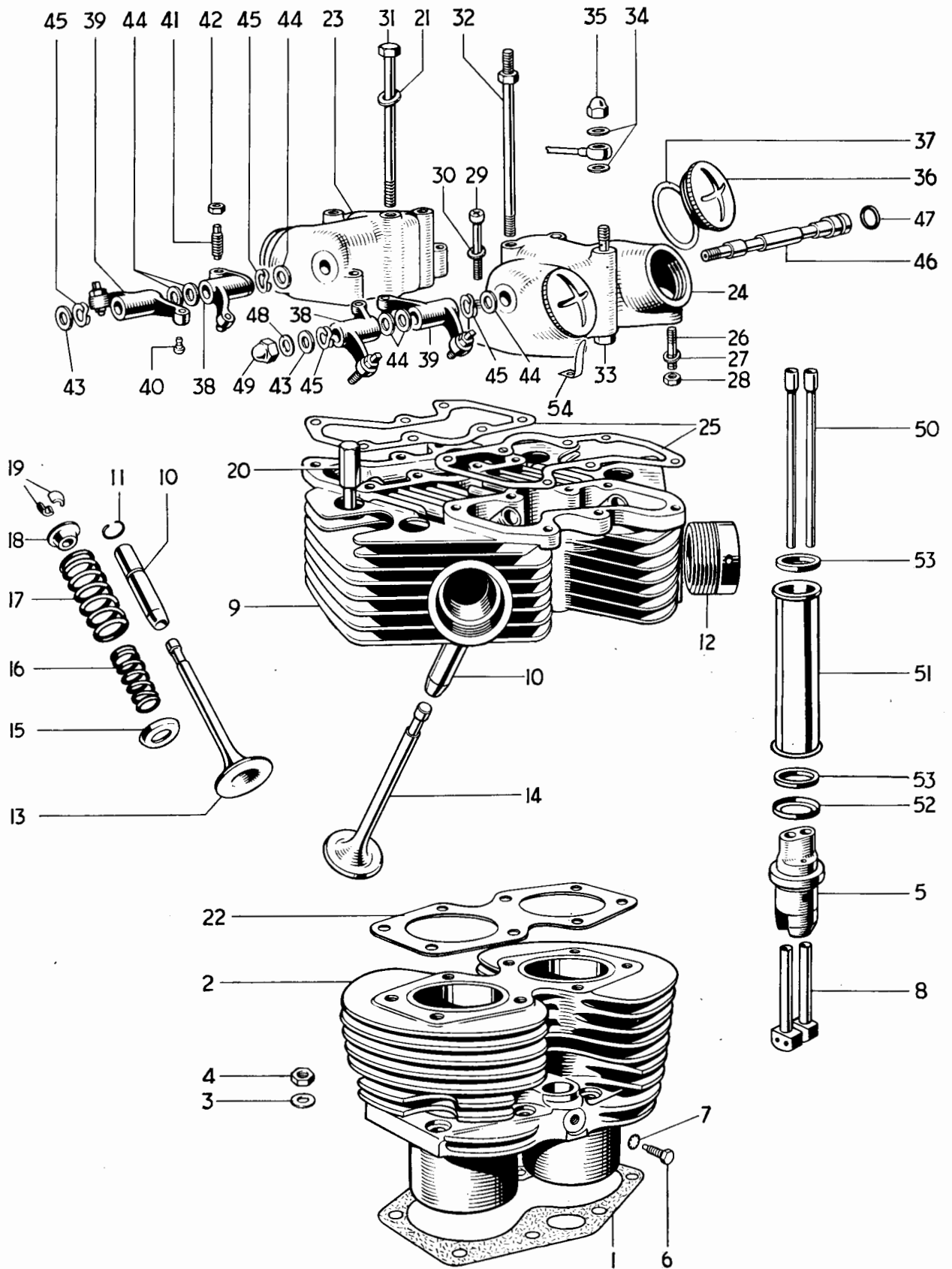

Fig. 4. CYLINDER BLOCK AND HEAD, 3TA AND T90

CYLINDER BLOCK AND HEAD, 3TA AND T90*(Continued)*

49	E1435	Domed nut	2
50	E3759	Push rod	4
51	E4751	Cover tube	2
52	E4746	Bottom cup	2
53	E4752	Rubber washer	4
54	E4671	Locking spring	4

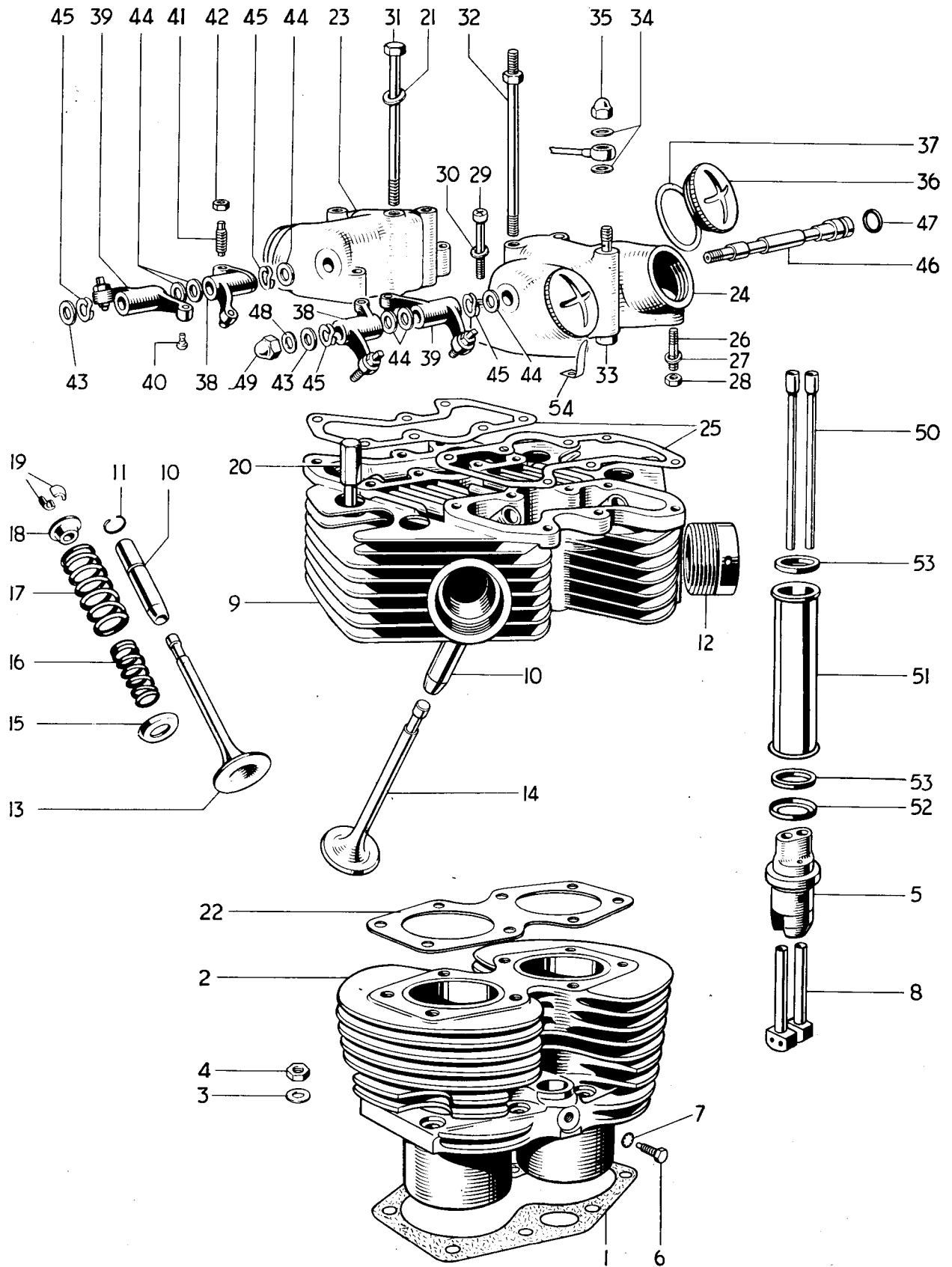
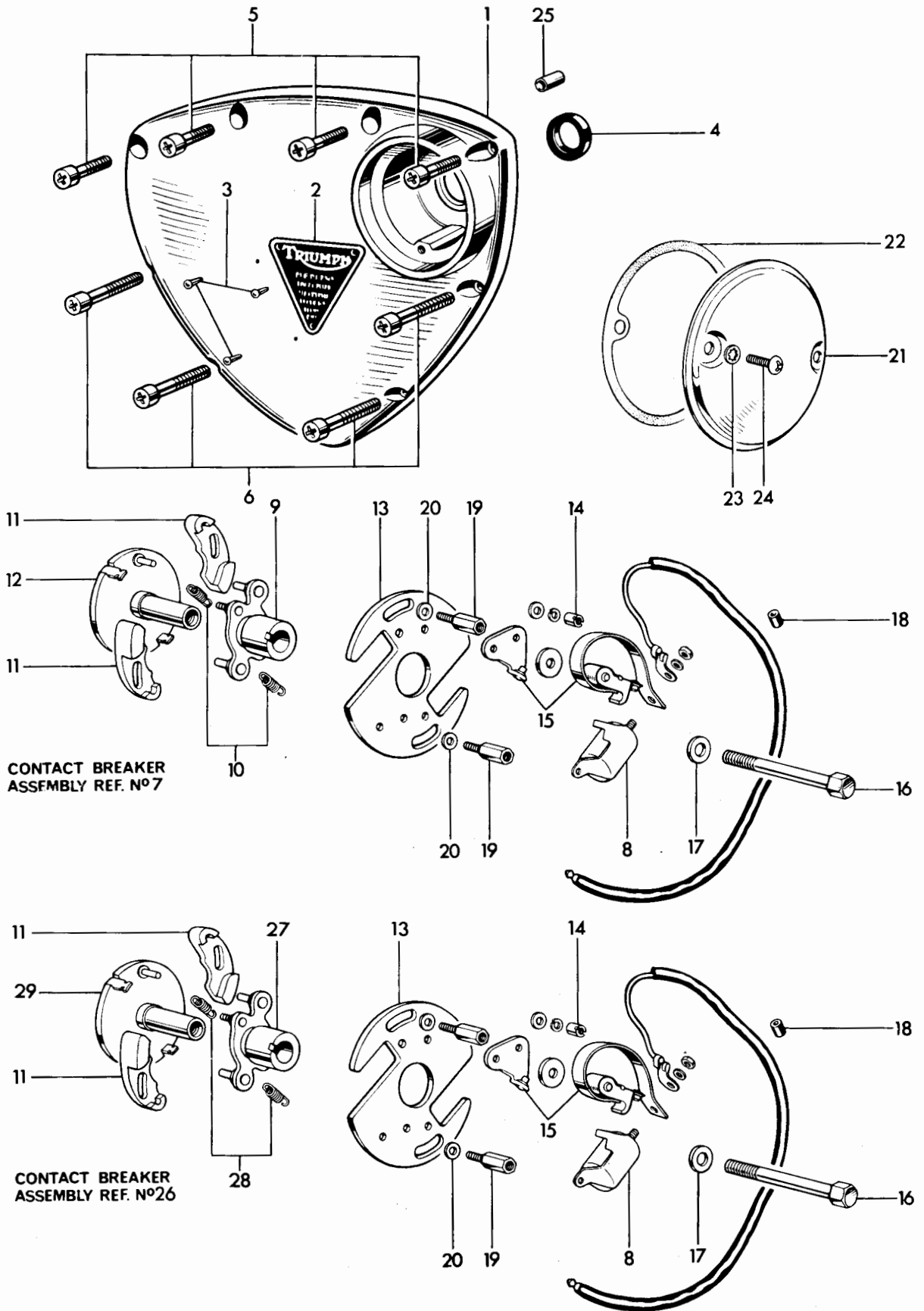

Fig. 5. CYLINDER BLOCK AND HEAD, 5TA AND T100

CYLINDER BLOCK AND HEAD, 5TA AND T100

Ref. No.	Part No.	Description	Quantity	Remarks
1	E3798	Cylinder base washer	1	
2	E4000	Cylinder block	1	
3	GS308	Plain washer	8	
4	E2412	Nut	8	
5	E4676	Tappet guide block	2	
6	H200	Tappet block screw ($\frac{7}{16}$ in. U.H.)	2	
7	E1612	Serrated washer	2	
8	E3753	Tappet	4	
9	E4785	CYLINDER HEAD c/w GUIDES	1	
10	E3208	Valve guide <i>... O.V.E.T. SIZE guide E10229</i>	4	5TA
10	E6301	Valve guide	4	T100
11	E3209	Valve guide circlip	4	
12	E2961	Exhaust pipe adaptor	2	
13	E4012	Inlet valve	2	
14	E4013	Exhaust valve	2	
15	E3740	Bottom cap	4	
16	E5946	Inner valve spring	4	
17	E4011	Outer valve spring	4	
18	E3742	Top collar	4	
19	WE259A	Split cotter	8	
20	E4456	Cylinder head bolt (2 $\frac{25}{32}$ in. U.H.)	4	
21	F2184	Plain washer	8	
22	E4675	Cylinder head gasket	1	
23	E3745	Inlet rocker box	1	
24	E3744	Exhaust rocker box	1	
25	E3743	Joint washer	2	
26	E3858	Rocker box stud ($\frac{1}{8}$ in. O.A.)	4	
27	E3302	Plain washer	4	
28	F879	Nut	4	
29	E3668	Screw ($\frac{1}{8}$ in. U.H.)	4	
30	E3857	Plain washer	4	
31	E3794	Cylinder head bolt (5 $\frac{7}{16}$ in. U.H.)	2	
32	E3795	Cylinder head torque stay bolt	2	
33	E3809	Oil feed bolt	2	
34	F1880	Copper washer	6	
35	E400	Domed nut	2	
36	E4610	Inspection cap	4	
37	E3751	Fibre washer	4	
38	E3749	ROCKER (right exhaust, left inlet)	2	
39	E3750	ROCKER (left exhaust, right inlet)	2	
40	E3222	Rocker ball pin	4	
41	E3223	Rocker adjusting pin	4	
42	GS662	Adjuster lock nut	4	
43	E1330	Thrust washer, $\frac{3}{8}$ in.	4	
44	E2534	Thrust washer, $\frac{7}{16}$ in.	6	
45	E3224	Spring washer	2	
46	E3748	Rocker spindle	2	
47	E3253	Sealing rubber	2	
48	E1335	Copper washer	2	
49	E1435	Domed nut	2	
50	E4008	Push rod	4	
51	E4751	Cover tube	2	
52	E4746	Bottom cup	2	
53	E4752	Rubber washer	4	
54	E4671	Locking spring	4	



CONTACT BREAKER
ASSEMBLY REF. N°7

CONTACT BREAKER
ASSEMBLY REF. N°26

Fig. 6. TIMING COVER AND CONTACT BREAKER

TIMING COVER AND CONTACT BREAKER

Ref. No.	Part No.	Description	Quantity	Remarks
1	E4630	Timing cover	1	
2	E4016	Patent plate	1	
3	D208-5	Hammer-drive screw	3	
4	E4568	Oil seal	1	
5	E3800	Screw ($\frac{7}{8}$ in. U.H.)	4	
6	E3801	Screw ($1\frac{1}{8}$ in. U.H.)	4	
7	47605	CONTACT BREAKER, type 4CA	1	} Coil Ignition
8	425377	Condenser	2	
9	54441729	Cam... ..	1	
10	54415642	Spring set	1	
11	425359	Weight	2	
12	54415751	Sleeve and action plate	1	
13	425370	Base plate	1	
14	169194	Slotted nut... ..	4	} A.C. Ignition
15	54415803	Contact set	2	
16	E5451	Bolt (2 in. U.H.)	1	
17	S25-43	Plain washer	1	
18	E4707	Grommet	1	
19	E4747	Pillar bolt	2	
20	E6559	Plain washer	2	
21	E4571	Cover	1	
22	E5049	Joint washer	1	
23	GS299	Serrated washer	2	
24	F4715	Screw ($15/32$ in. U.H.)	2	
25	T989	Hollow dowel	1	
26	47602	CONTACT BREAKER, type 4CA	1	} A.C. Ignition
8	425377	Condenser	2	
27	54415473	Cam... ..	1	
29	54415641	Spring set	1	
11	425359	Weight	2	
29	54415747	Sleeve and action plate	1	
13	425370	Base plate	1	
14	169194	Slotted nut	4	
15	54415803	Contact set	2	

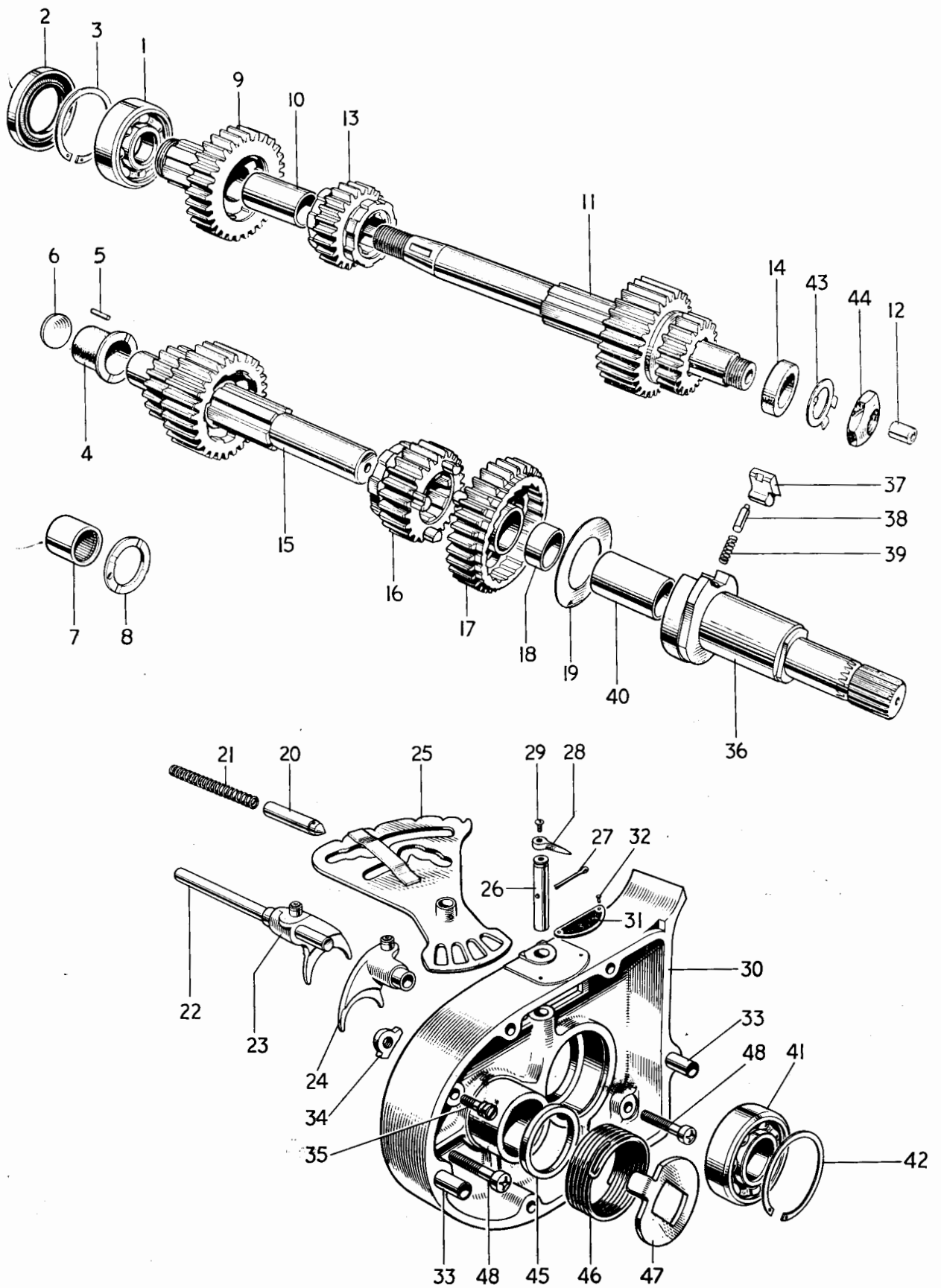

Fig. 7. GEARBOX SHAFTS, BEARINGS AND INNER COVER

GEARBOX SHAFTS, BEARINGS AND INNER COVER

Ref. No.	Part No.	Description	Quantity	Remarks
1	T665	High gear bearing (ball journal)	1	
2	T1478	Oil seal	1	
3	W680	Circlip	1	
4	T1367	Layshaft bush	1	3TA, 5TA
5	T912	Peg	1	
6	T981	Blanking disc	1	3TA, 5TA
7	T1606	Layshaft bearing	1	T90, T100
8	T1607	Thrust washer	1	T90, T100
9	T1947	MAINSHAFT HIGH GEAR (22T)	1	
10	T1405	High gear bush	1	
11	T1948	MAINSHAFT c/w THIRD AND LOW GEARS (16/24T)	1	<i>Wk T3275</i>
12	T1391	Clutch rod bush	1	
13	T1922	Mainshaft second gear (21T)	1	
14	T1411	Mainshaft distance piece	1	
15	T1965	Layshaft c/w second and high gears (15/23T)	1	3TA, 5TA
15	T1949	Layshaft c/w second and high gears (15/23T)	1	T90, T100
16	T1839	Layshaft third gear (20T)	1	
17	T1950	LAYSHAFT LOW GEAR (27T)	1	
18	T1393	Low gear bush	1	
19	T1426	Pawl retaining disc	1	
20	T1471	Camplate index plunger	1	
21	T373	Index plunger spring	1	
22	T1457	Selector fork spindle	1	
23	T1480	Mainshaft selector fork	1	
24	T1481	Layshaft selector fork	1	
25	T1768	Gear selector camplate	1	
26	T1418	Camplate spindle	1	
27	$\frac{1}{8}$ in. x $\frac{3}{4}$ in.	Split pin	1	
28	T1416	Gear indicator pointer	1	
29	H688	Screw ($\frac{5}{16}$ in. U.H.)	1	
30	T1448	Inner cover	1	
31	T417	Gear indicator plate	1	
32	D208-5	Indicator plate rivet	2	
33	T1440	Hollow dowel	2	
34	T1157	Kickstarter stop plate	1	
35	T1390	Stop plate and anchor screw	1	
36	T1445	KICKSTARTER SPINDLE	1	
36	T1981	KICKSTARTER SPINDLE	1	
37	T1431	Kickstarter pawl	1	
38	T1282	Plunger	1	
39	T1161	Plunger spring	1	
40	T1897	Bearing	1	
40	T1446	Floating bush	1	
41	T1469	Mainshaft bearing (Ball journal)	1	
42	T280	Circlip	1	
43	T732	Tab washer	1	
44	T2009	Mainshaft nut	1	
45	T1464	Distance piece	1	
46	T1441	Kickstarter return spring	1	
47	T1422	Return spring plate	1	
48	E3204	Screw (1 in. U.H.)	1	

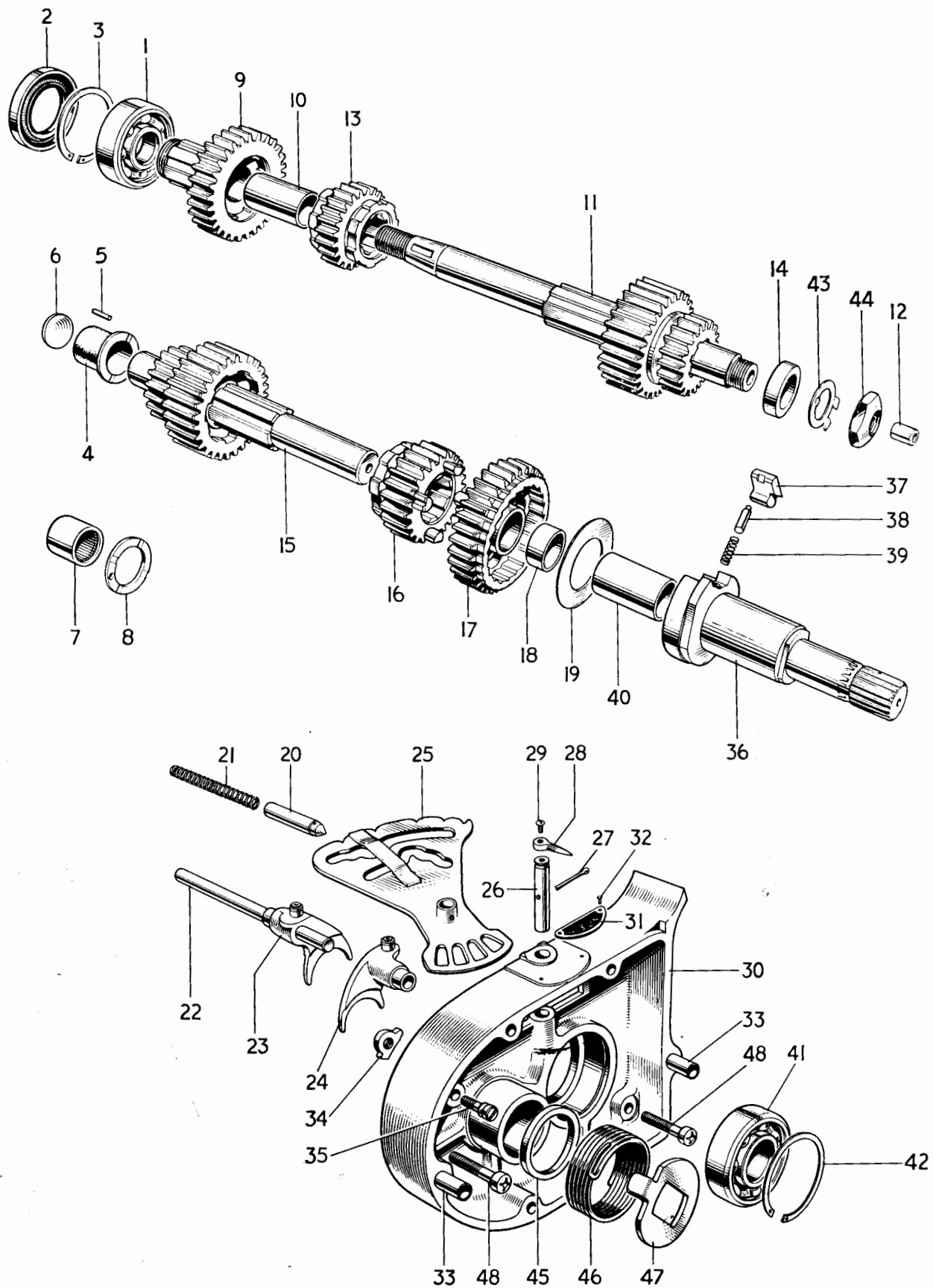

Fig. 7. GEARBOX SHAFTS, BEARINGS AND INNER COVER

WIDE RATIO GEARS

(Can be fitted to T90 or T100)

9	T1684	MAINSHAFT HIGH GEAR (23T)	1	} Standard on Eastern T100 C
11	T1959	MAINSHAFT c/w THIRD & LOW GEAR (15/24T)	1	
13	T1837	Mainshaft second gear (20T)	1	
15	T1960	Layshaft c/w second & high gear (14/24T)	1	
16	T1839	Layshaft third gear (20T)	1	
17	T1961	LAYSHAFT LOW GEAR (29T)	1	

CLOSE RATIO GEARS

(Can be fitted to T90 or T100)

9	T1821	MAINSHAFT HIGH GEAR (20T)	1
11	T1971	MAINSHAFT c/w THIRD & LOW GEAR (16/22T)	1
13	T1832	Mainshaft second gear (20T)	1
15	T1972	Layshaft c/w second and high gear (17/23T)	1
16	T1842	Layshaft third gear (21T)	1
17	T1950	LAYSHAFT LOW GEAR (27T)	1

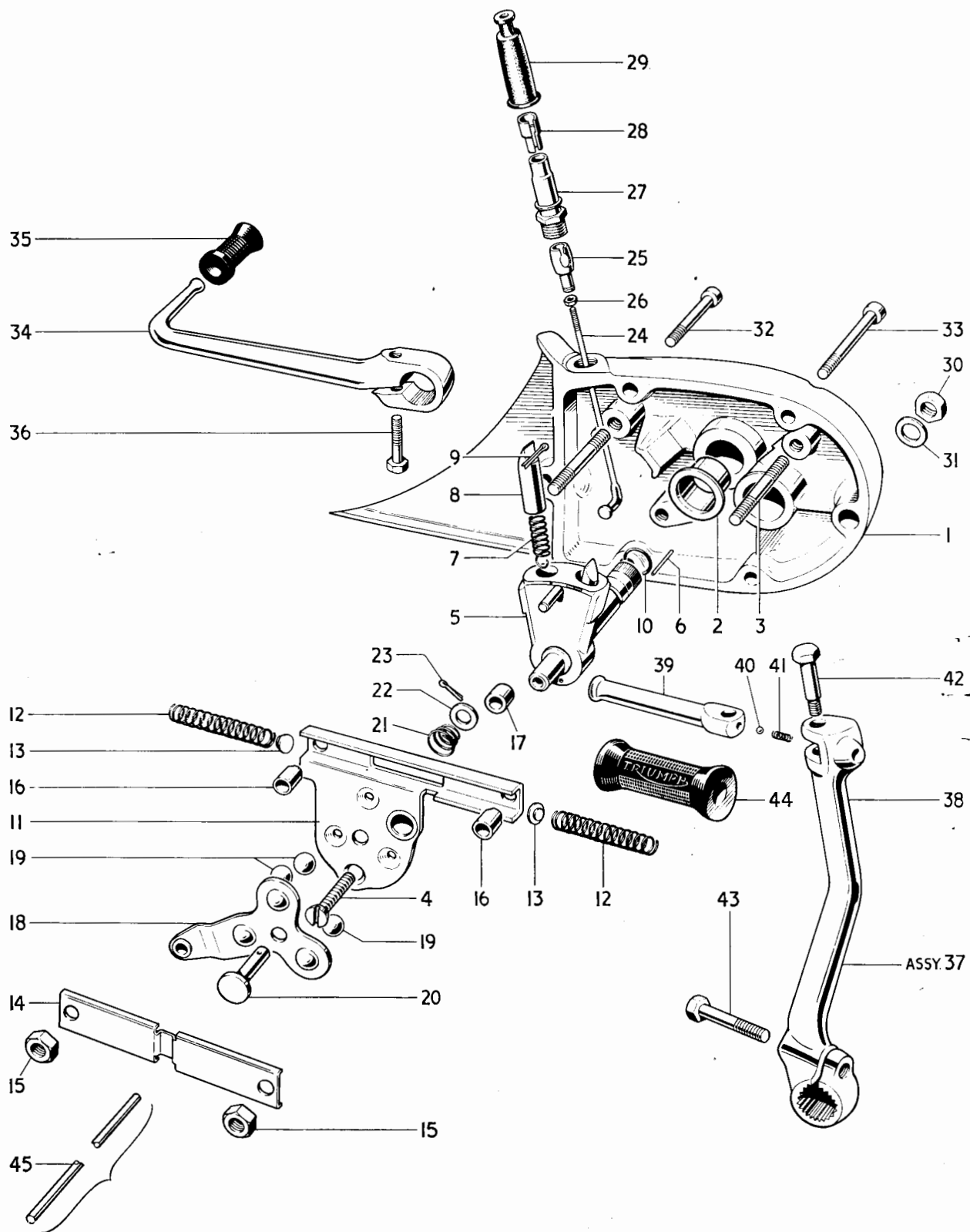

Fig. 8. GEARBOX OUTER COVER AND LEVERS

GEARBOX OUTER COVER AND LEVERS

1	T1870	GEARBOX OUTER COVER	1	
2	T1395	Gearchange spindle bush...	1	
3	T1944	Stud (1 $\frac{5}{8}$ in. O.A.)	2	
4	T1875	Screw ($\frac{7}{8}$ in. O.A.)	1	
5	T1942	GEARCHANGE QUADRANT	1	
6	T1474	Spring retaining pin	2	
7	T1436	Plunger spring	2	
8	T1396	Selector plunger	2	
9	5/64 in. x $\frac{5}{8}$ in.	Split pin	2	
10	E3309	Sealing ring	1	
11	T1871	Return spring housing	1	
12	T1877	Return spring	2	
13	T1878	Thrust button	2	
14	T1977	Cover	1	
15	W103	Nut	3	
16	T1876	Distance piece	2	
17	T1874	Distance piece	1	
18	T1880	Clutch lever	1	
19	T1771	Ball, $\frac{3}{8}$ in. diam.	3	
20	T1710	Shaft	1	
21	T1712	Spring	1	
22	GS127	Plain washer	1	
23	5/64 in. x $\frac{1}{2}$ in.	Split pin	1	
24	T1945	Spoke	1	
25	T1946	Connector	1	
26	T1937	Nut	1	
27	T1644	Abutment	1	
28	T2062	Adaptor, short	As required	
28	T2063	Adaptor, long (For cable with short outer cover)...	As required	
29	T1646	Rubber cover	1	
30	S1-51	Nut	2	
31	S25-3	Plain washer	2	
32	T1401	Screw (2 $\frac{3}{8}$ in. U.H.)	2	
33	T1402	Screw (2 $\frac{5}{8}$ in. U.H.)	2	
34	T1435	Gearchange lever	1	
35	T449	Pedal rubber	1	
36	W932	Bolt (1 in. U.H.)	1	
37	T1677	KICKSTARTER LEVER COMPLETE...	1	
38	T1678	Kickstarter crank	1	
39	T1272	Kickstarter pedal	1	
40	S70-3	Steel ball ($\frac{1}{4}$ in. diam.)	1	
41	T1167	Index spring	1	
42	T1273	Pivot bolt	1	
43	T1439	Clamp bolt (1 $\frac{3}{8}$ in. U.H.)	1	
44	F1814	Pedal rubber	1	
45	T1456	Clutch operating rod	1	3TA
45	T1970	Clutch operating rod	1	5TA, T90, T100

CLUTCH ASSEMBLY No 1

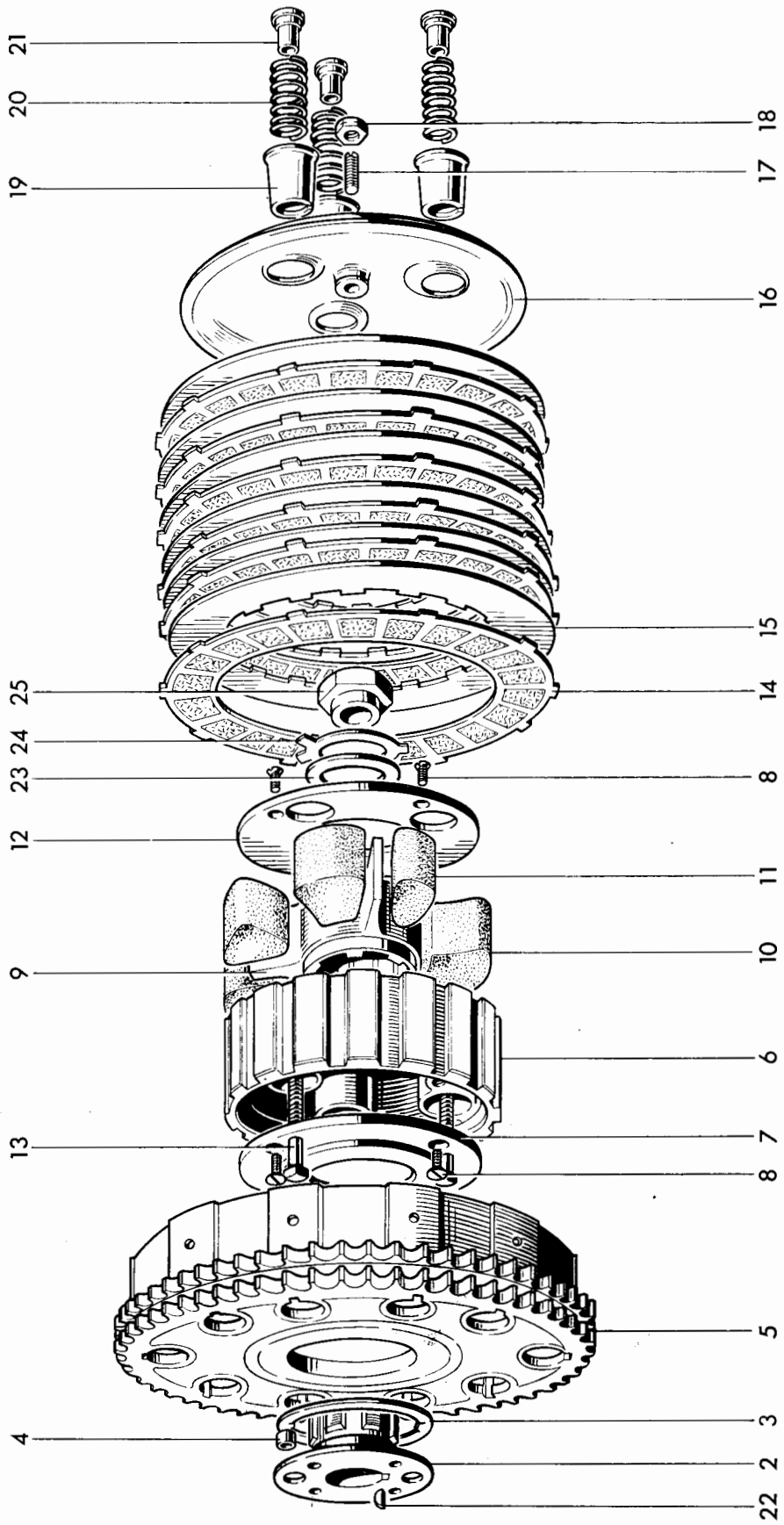

Fig. 9. CLUTCH

CLUTCH

Ref. No.	Part No.	Description	Quantity	Remarks
1	T1933	CLUTCH COMPLETE	1	3TA
1	T1935	CLUTCH COMPLETE	1	5TA, T90, T100
2	T1751	Hub	1	
3	T1735	Thrust washer	1	
4	T394	Roller	20	
5	T1442	Sprocket and housing	1	3TA
5	T1570	Sprocket and housing	1	5TA, T90, T100
6	T1718	Centre (Shock absorber body)	1	3TA
6	T1719	Centre (Shock absorber body)	1	5TA, T90, T100
7	T1720	Inner plate	1	
8	T1040	Countersunk screw (0.417 in. U.H.)	6	
9	T1721	Shock absorber spider	1	
10	T1722	Drive rubber (large)	3	
11	T1723	Rebound rubber (small)	3	
12	T1724	Outer plate	1	
13	T423	Screwed pin (1 19/32 in. U.H.)	3	3TA
13	T423A	Screwed pin (1 27/32 in. U.H.)	3	5TA, T90, T100
14	T1362	Driving plate (bonded)	5	6 off 5TA, T90, T100
15	T1363	Driven plate (plain)	5	6 off 5TA, T90, T100
16	T2156	Pressure plate	1	
17	T2159	Adjuster pin	1	
18	13206/00/1	Nut	1	
19	T1934	Spring cup	3	3TA
19	T1931	Spring cup	3	5TA, T90, T100
20	T1752	Spring	3	3TA
20	T1560	Spring	3	5TA, T90, T100
21	T427	Brass nut	3	
22	S66-1	Key	1	
23	T1045	Cupped washer	1	
24	T1046	Tab washer	1	
25	T1047	Nut	1	

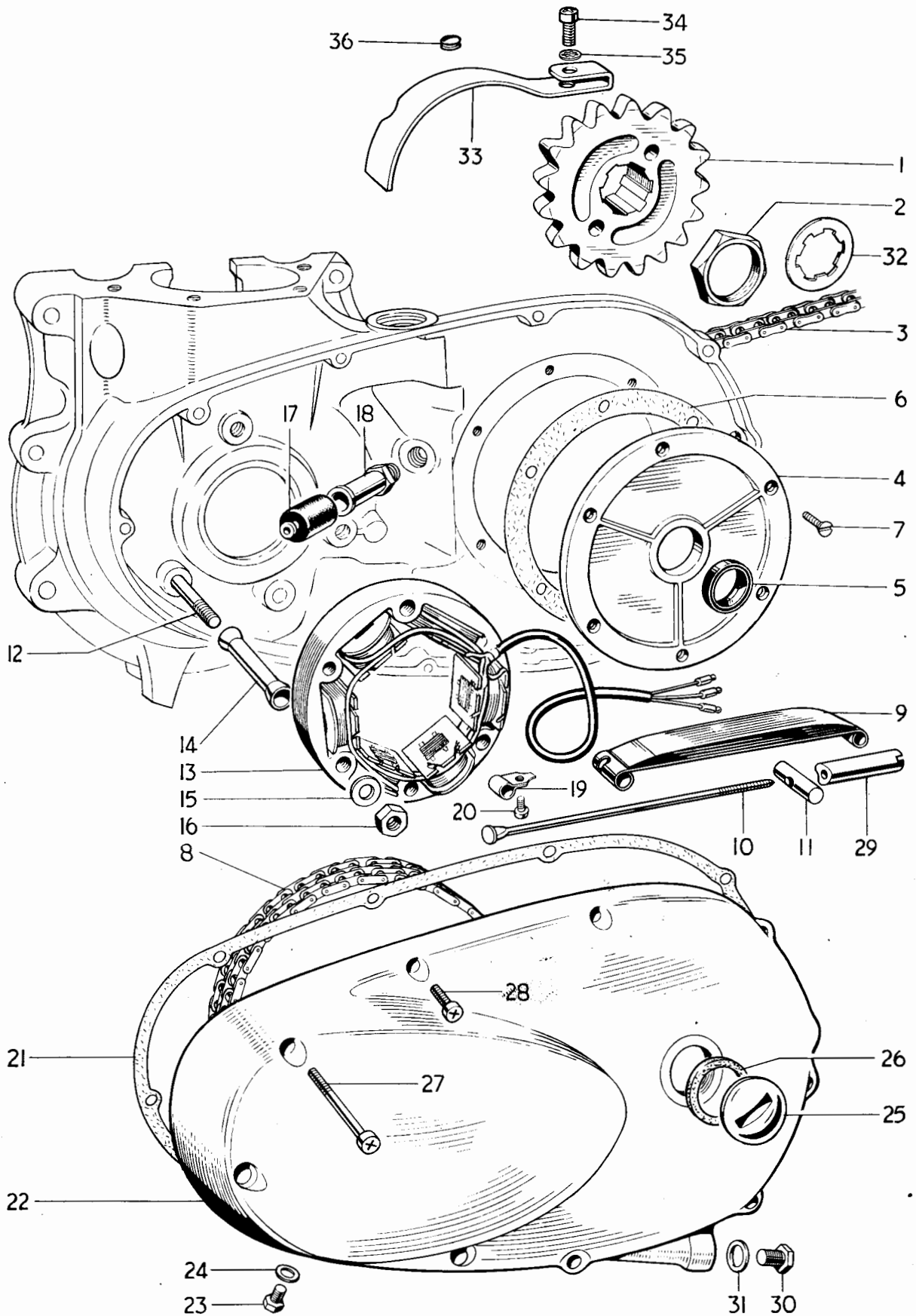

Fig. 10. CHAINCASE AND CHAINS

CHAINCASE AND CHAINS

Ref. No.	Part No.	DESCRIPTION	QUANTITY	REMARKS
1	T1558	Gearbox sprocket (17 teeth) ...	1	3TA, T90
1	T1476	Gearbox sprocket (18 teeth) ...	1	T100, T100C
1	T1476/19	Gearbox sprocket (19 teeth) ...	1	5TA, T100R
1	T1569	Gearbox sprocket (20 teeth) ...	1	
2	T1434	Gearbox sprocket nut ...	1	
3	D444	Rear chain, $\frac{5}{8}$ in. x $\frac{3}{8}$ in. x 102L ...	1	3TA, T90, T100
3	D481	Rear chain, $\frac{5}{8}$ in. x $\frac{3}{8}$ in. x 103L ...	1	5TA
4	E3789	Cover plate ...	1	
5	E3833	Oil seal ...	1	
6	E3832	Joint washer ...	1	
7	E3821	Countersunk screw ($\frac{5}{16}$ in. U.H.) ...	6	
8	D358	Primary chain, $\frac{3}{8}$ in. Duplex 78L ...	1	
9	E6283	Chain tensioner blade ...	1	
10	E4152	Tie rod ...	1	
11	E5977	Trunnion ...	1	
12	E3811	Stud (3 $\frac{5}{16}$ in. O.A.) ...	3	
13	47162	Stator, RM 19 ...	1	Coil Ignition
13	47188	Stator, R.M.19 ...	1	A.C. Ignition
14	E3810	Distance piece ...	3	
15	S25-3	Plain washer ...	3	
16	E5324	Nut ...	3	
17	E4144	Rubber grommet ...	1	
18	E5872	Sleeve nut ...	1	
19	E1509	Clip ...	1	
20	T361	Bolt ($\frac{1}{4}$ in. U.H.) ...	1	
21	E4156	Joint washer ...	1	
22	E4122	Chaincase ...	1	
23	DS57	Drain and level plug ...	1	
24	WE170	Fibre washer ...	2	
25	E732	Filler plug ...	1	
26	NE507	Fibre washer ...	1	
27	E3802	Screw (2 $\frac{3}{4}$ in. U.H.) ...	3	
28	E3668	Screw (1 $\frac{5}{8}$ in. U.H.) ...	7	
29	E4153	Adjuster sleeve nut ...	1	
30	E4154	Drain plug ...	1	
31	T1738	Fibre washer ...	1	
32	T2056	Tab washer ...	1	
33	E6186	Crankcase protector ...	1	
34	T1553	Screw ($\frac{3}{8}$ in. U.H.) ...	1	} T90, T100
35	E1612	Serrated washer ...	1	
36	E6226	Rubber plug ...	1	3TA, 5TA

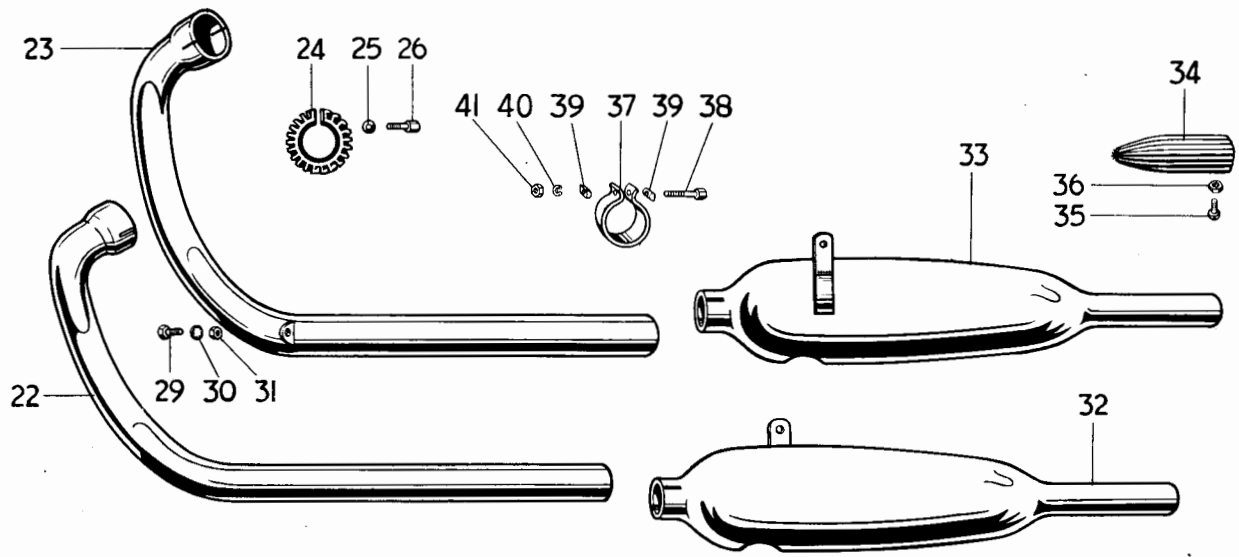
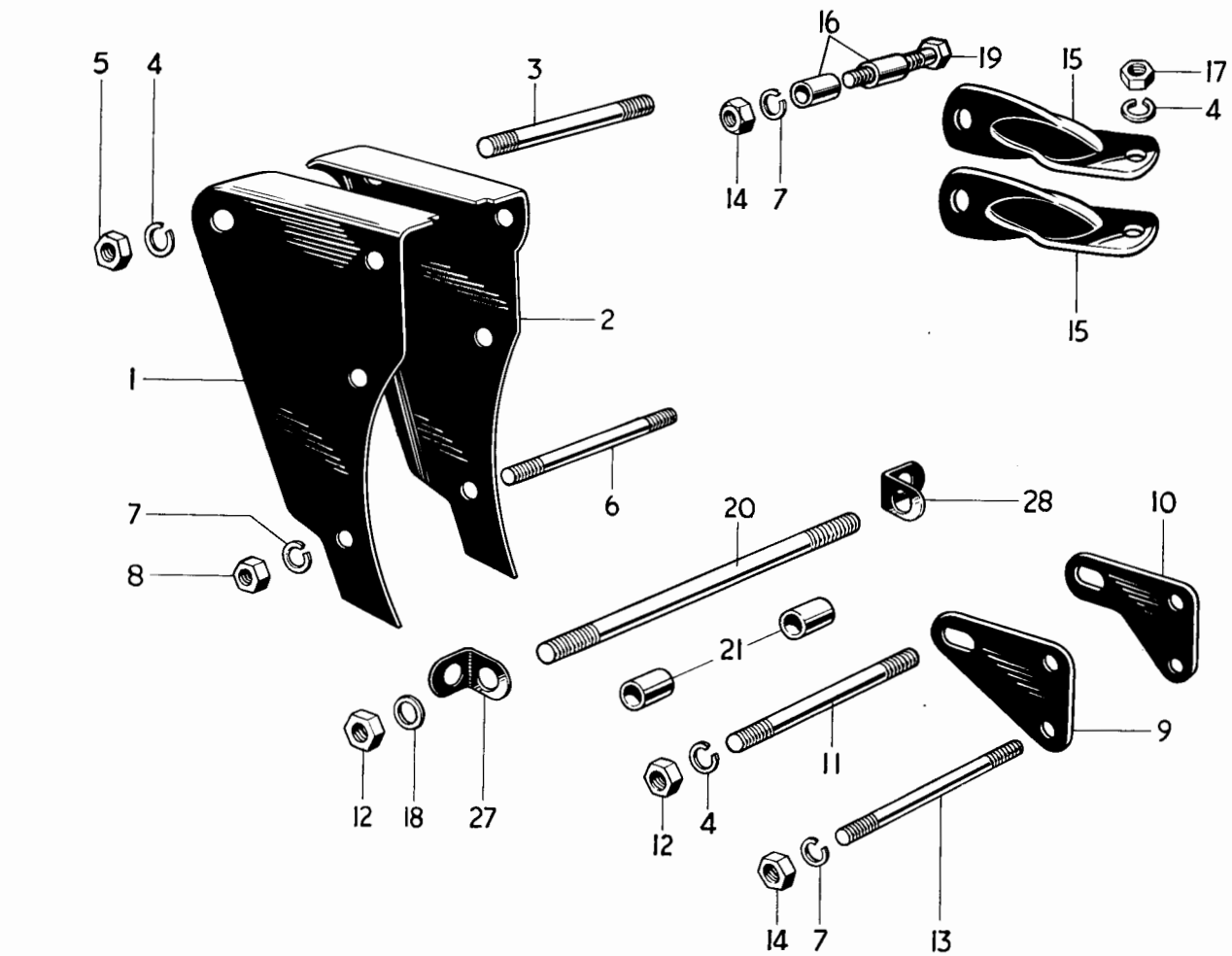

Fig. 11. ENGINE FITTINGS AND EXHAUST SYSTEM

ENGINE FITTINGS AND EXHAUST SYSTEM

Ref. No.	Part No.	DESCRIPTION	QUANTITY	REMARKS
1	F4275	Left front engine plate...	1	
2	F4276	Right front engine plate	1	
3	F2825	Stud (3 $\frac{1}{4}$ in. O.A.)	1	
4	S26-1	Spring washer	8	
5	PO172A	Nut	2	
6	E3804	Stud (3 in. O.A.)	3	
7	S26-3	Spring washer	8	
8	S1-51	Nut	3	
9	F4229	Left rear engine plate	1	
10	F4230	Right rear engine plate	1	
11	E3665	Stud (4 $\frac{1}{4}$ in. O.A.)	1	
12	PO172A	Nut	4	
13	E3695	Stud (4 $\frac{5}{16}$ in. O.A.)	2	
14	S1-51	Nut	5	
15	E4778	Torque stay	2	
16	E5072	Distance piece	2	
17	S1-52	Nut	2	
18	F5532	Plain washer	2	
19	E4165	Bolt (1 $\frac{1}{8}$ in. U.H.)	1	
20	E3812	Stud (7 $\frac{1}{2}$ in. O.A.)	1	
21	F4197	Distance piece	2	
22	E3992	Left exhaust pipe	1	5TA, T100
23	E3994	Right exhaust pipe	1	5TA, T100
22	E5325	Left exhaust pipe	1	3TA, T90
23	E5327	Right exhaust pipe	1	3TA, T90
24	E4947	Finned clip	2	
25	E410A	Hemispherical washer	2	
26	E409	Bolt (1 $\frac{3}{8}$ in. U.H.)	2	
27	F4707	Left bracket	1	
28	F4283	Right bracket	1	
29	DS57	Bolt ($\frac{7}{8}$ in. U.H.)	2	
30	E1612	Serrated washer	2	
31	F879	Nut	2	
32	E3935	Left silencer	1	
32	E4157	Left muffler	1	T100R
33	E3936	Right silencer	1	
33	E4158	Right muffler	1	T100R
34	E4155	Silencer mute		As required
35	H689	Screw ($\frac{1}{4}$ in. U.H.)		As required
36	H691	Nut		As required
37	E2271	Clip	2	
38	F3430	Bolt (1 $\frac{3}{4}$ in. U.H.)	2	
39	E3768	"D" washer	4	
40	S26-3	Spring washer	2	
41	E1310	Nut	2	

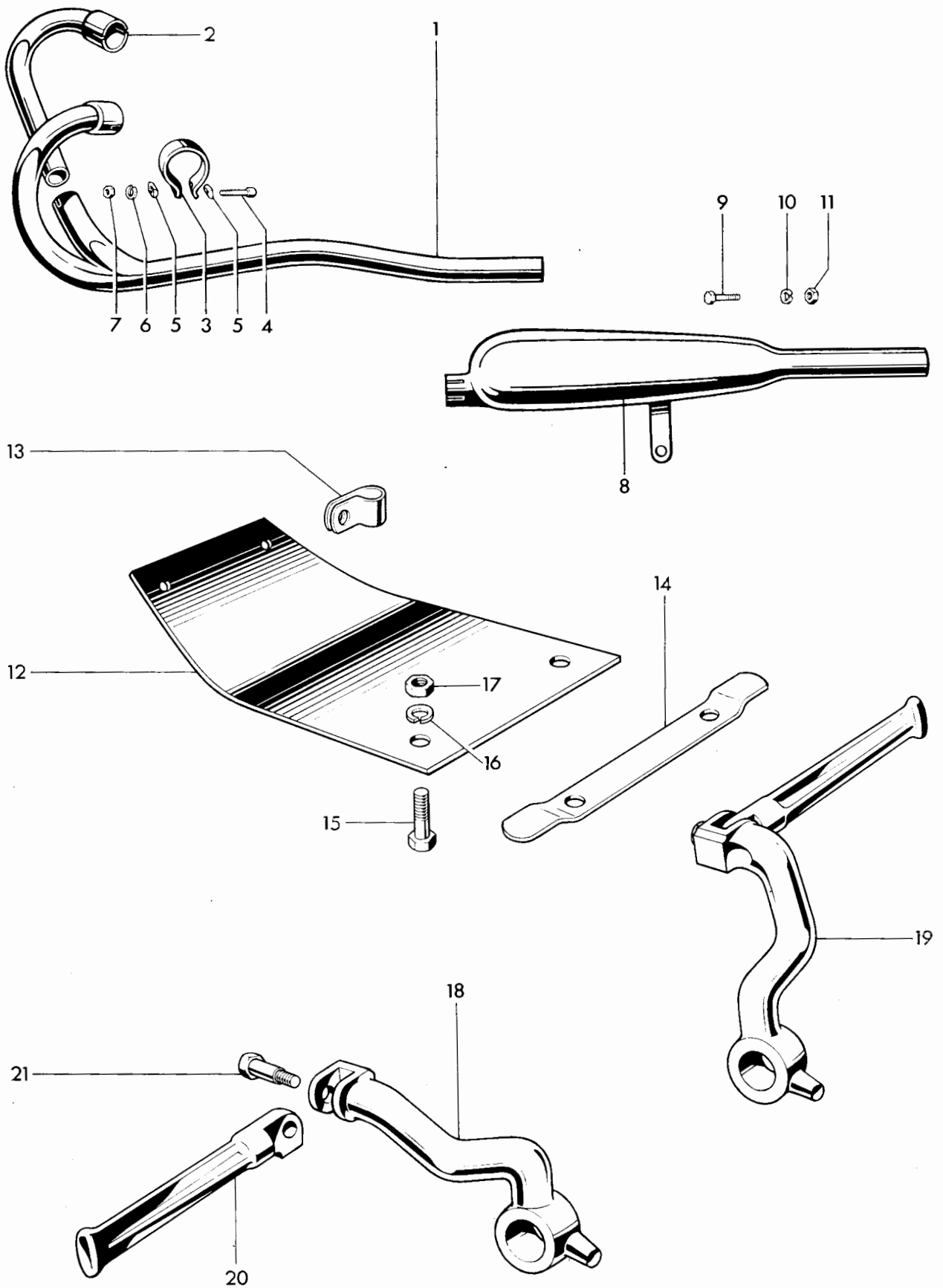

Fig. 12. EXHAUST PIPES, UNDERSHIELD AND FOOTPEGS (T100C)

EXHAUST PIPES, UNDERSHIELD AND FOOTPEGS (T100C)

Ref. No.	Part No.	Description	Quantity
1	E4513	Left Exhaust pipe	1
2	E4514	Right exhaust pipe	1
3	E5874	Clip	1
4	F3430	Bolt	1
5	E3768	"D" Washer	2
6	S26-3	Spring Washer	1
7	E1310	Nut	1
8	E3470	Muffler	1
9	H426	Bolt ($\frac{3}{8}$ in. U.H.)	1
10	S26-1	Spring washer	1
11	S1-51	Nut	1
12	F4852	Undershield	1
13	F1700	Clip	2
14	F3078	Bracket	1
15	F1369	Bolt ($\frac{5}{8}$ in. U.H.)	4
16	S26-2	Spring washer	4
17	F879	Nut	4
18	F7018	LEFT FOLDING FOOTPEG	1
19	F7019	RIGHT FOLDING FOOTPEG	2
20	F6411	Pedal	2
21	F6655	Pivot bolt	2

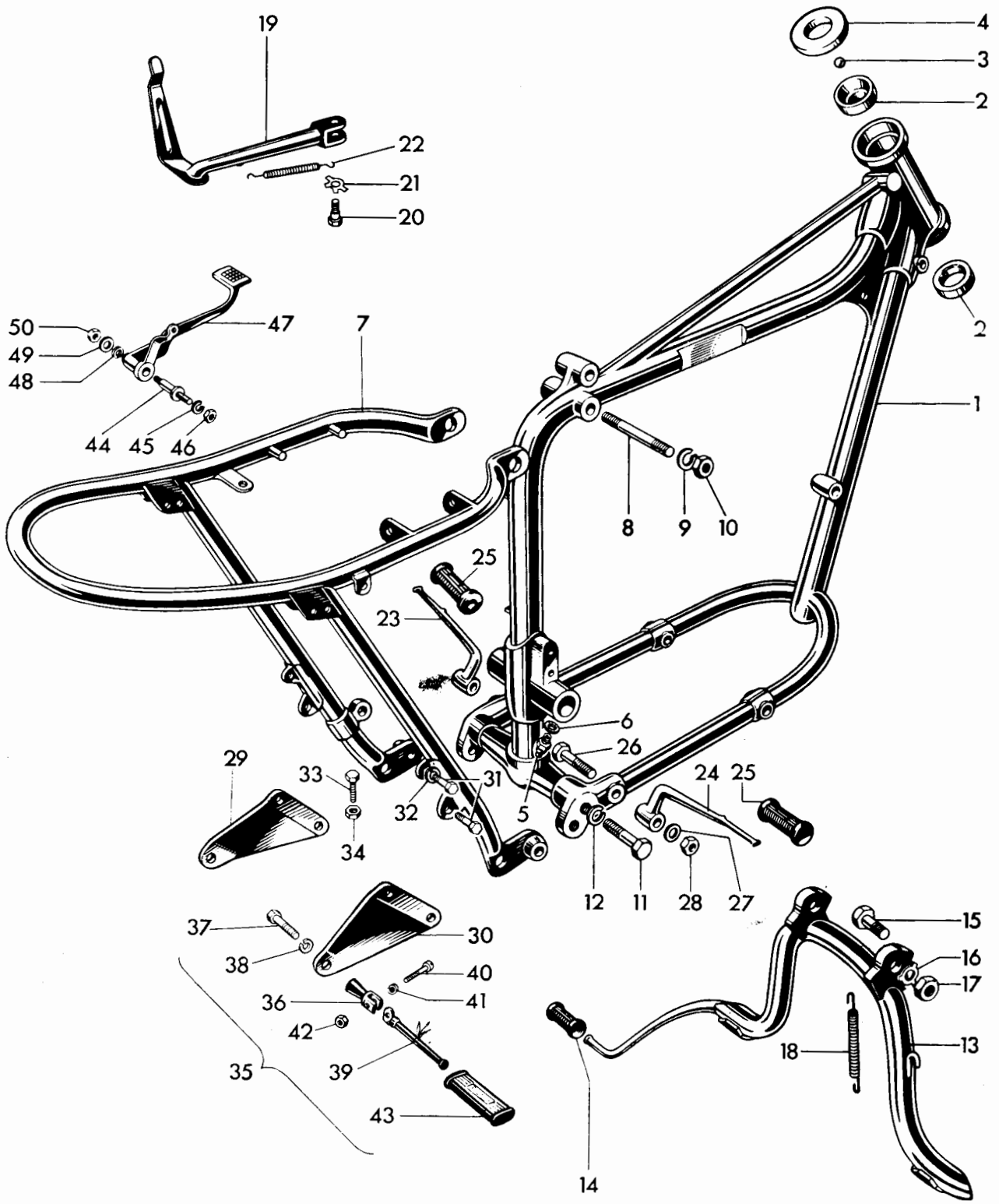

Fig. 13. FRAME

FRAME

1	F6912	Front frame	1	
2	H1130	Steering race cup	2	
3	S70-4	Steel ball ($\frac{3}{8}$ in. U.H.)	48	
4	H1140	Top cone and dust cover	1	
5	NW100	Grease nipple	1	
6	WE170	Fibre washer	1	
7	F6913	Rear frame	1	
8	F2842	Stud ($4\frac{3}{8}$ in. O.A.)	1	
9	S26-1	Spring washer	2	
10	S1-52	Nut	2	
11	F3780	Bolt ($1\frac{1}{8}$ in. U.H.)	2	
12	PCW73A	Spring washer	2	
13	F4891	Centre stand	1	T100R
13	F5153	Centre stand	1	
14	T449	Pedal rubber	1	
15	F3619	Pivot bolt ($1\frac{3}{8}$ in. U.H.)	2	
16	F4484	Tab washer	2	
17	F2725	Nut	2	
18	F3617	Return spring	1	
19	F5539	Prop stand	1	T100C, T100R
19	F3723	Prop stand	1	
20	F3097	Pivot bolt	1	
21	F3096	Tab washer	1	
22	F2610	Return spring	1	
23	F4214	Left footrest	1	
24	F4215	Right footrest	1	
25	NF704	Pedal rubber	2	
26	F4369	Bolt ($2\frac{1}{8}$ in. U.H.)	2	
27	F4370	Plain washer	2	
28	DS47	Nut	2	
29	F5087	Left pillion footrest support	1	
30	F5088	Right pillion footrest support	1	
31	DS58	Bolt ($\frac{3}{2}$ in. U.H.)	4	
32	S26-3	Spring washer	4	
33	F1149	Pedal stop screw ($\frac{1}{8}$ in. U.H.)	1	
34	F879	Nut	1	
35	F5552	PILLION FOOTREST	2	
36	F2268	Footrest hanger	2	
37	F5535	Bolt ($\frac{13}{16}$ in. U.H.)	2	
38	S26-1	Spring washer	2	
39	F1694	Pedal	2	
40	F2271	Pivot bolt	2	
41	F2277	Spring washer	2	
42	S1-51	Nut	2	
43	F1695	Pedal rubber	2	
44	F4284	Brake pedal spindle	1	
45	SCZ45	Spring washer	1	
46	DS48	Nut	1	
47	F4314	Brake pedal	1	
48	S26-16	Spring washer	1	
49	S25-2	Plain washer	1	
50	S1-52	Nut	1	

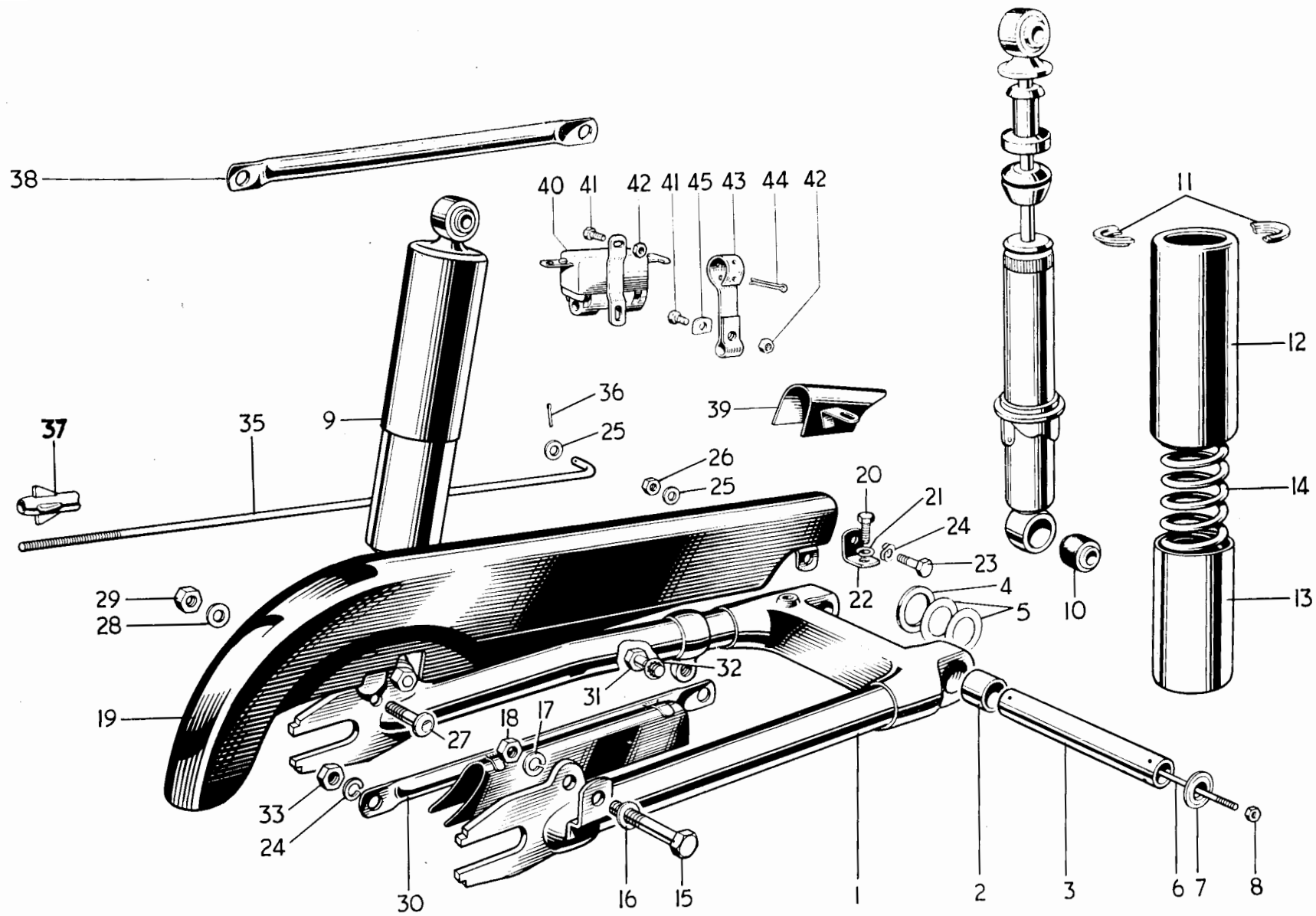

Fig. 14. SWINGING FORK, SUSPENSION UNITS AND CHAINGUARD

SWINGING FORK, SUSPENSION UNITS AND CHAINGUARD

Ref. No.	Part No.	DESCRIPTION	QUANTITY	REMARKS
1	F6936	SWINGING FORK	1	
2	F4076	Pivot bush	2	
3	F4195	Spindle	1	
4	F4078	Spacing washer	1	
5	F4385	Shim 0.003 in.	as required	
5	F4386	Shim 0.005 in.	as required	
6	F3797	Retainer rod	1	
7	F4196	Cap	2	
8	F3799	Nut	2	
9	64053946	SUSPENSION UNIT	2	
9	64054164	SUSPENSION UNIT	2	T100C, T100R
10	9054/316A	Bonded bush	4	
11	9054/171	Spring retainer	4	
12	9054/151	Outer dirt shield	2	
13	9054/47	Inner dirt shield	2	
14	64539963	Spring, 130 lbs. Red/Orange	2	
14	9054/277	Spring, 110 lbs. Red/Red	as required	
14	SA253/5	Spring, 145 lbs. Blue/Yellow	as required	
15	E2113	Unit fixing bolt (1 $\frac{1}{8}$ in. U.H.)	4	
16	F2184	Plain washer	2	
17	S26-1	Spring washer	2	
18	PO172A	Nut	2	
19	F5409	Upper chainguard	1	
20	DS57	Bolt ($\frac{7}{8}$ in. U.H.)	1	
21	S26-2	Spring washer	1	
22	F4134	Front bracket	1	
23	F4135	Pivot bolt	1	
24	F2277	Spring washer	1	
25	S25-13	Plain washer	2	
26	E5269	Nut	1	
27	F4136	Stepped bolt	1	
28	S25-3	Plain washer	1	
29	S1-51	Nut	1	
30	F4199	Lower chainguard	1	3TA, 5TA
31	W840	Bolt (17/32 in. U.H.)	1	
32	E2288	Serrated washer	1	
33	DS47	Nut	1	
34	PCW73A	Spring washer	1	
35	F3597	Brake operating rod	1	
36	$\frac{1}{8}$ in. x $\frac{3}{8}$ in.	Split pin	1	
37	F4585	Adjuster nut	1	
38	F4201	Brake torque stay	1	T90, T100
39	F6046	Front chainguard	1	
40	31383	Stop lamp switch, type 22 B	1	
41	T1076	Bolt ($\frac{3}{8}$ in. U.H.)	3	
42	F4717	Self locking nut	5	
43	F5687	Lever	1	
44	3/32 in. x $\frac{7}{8}$ in.	Split pin	1	
45	F5413	"D" washer	1	

FORK ASSEMBLY REF. N° 1

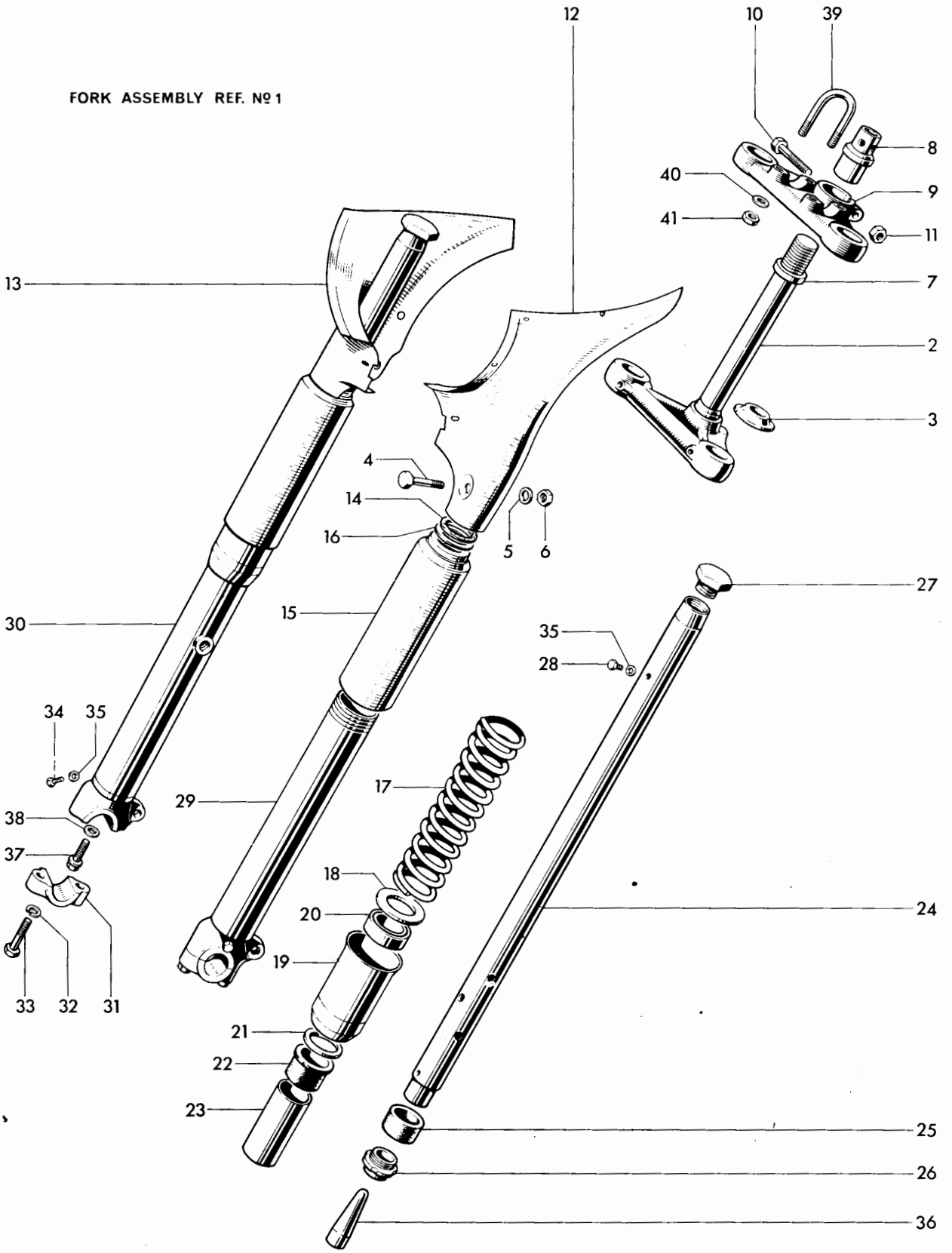

Fig. 15. TELESCOPIC FRONT FORK, 3TA AND 5TA

TELESCOPIC FRONT FORK, 3TA AND 5TA

Ref. No.	Part No.	Description	Quantity	Remarks
1	H2014	FORK ASSEMBLY	1	
2	H1328	Middle lug and stem	1	
3	H1110	Bottom cone	1	
4	H941	Pinch bolt (2 $\frac{1}{4}$ in. U.H.)	2	
5	S25-2	Plain washer	2	
6	H1335	Nut (2 $\frac{3}{8}$ in. O.A.)	2	
7	H1667	Distance piece	1	
8	H1141	Fork stem sleeve nut	1	
9	H1108	Top lug	1	
10	F1760	Pinch bolt (1 $\frac{1}{8}$ in. U.H.)	1	
11	H379	Seated nut	1	
12	H1290	Left nacelle cover	1	
13	H1291	Right nacelle cover	1	
14	F4047	Cork washer	2	
15	H1916	Upper cover tube	2	
16	H1745	Plain washer	2	
17	H1891	Main spring (Yellow/Blue)	2	
18	H1656	Plain washer	2	
19	H1654	DUST EXCLUDER SLEEVE NUT	2	
20	H1500	Oil seal	2	
21	H431	Plain washer	2	
22	H441	Top bearing	2	
23	H1896	Damping sleeve	2	
24	H1890	STANCHION c/w BEARING	2	
25	H443	Lower bearing	2	
26	H1058	Bearing nut	2	
27	H1659	Cap nut	2	
28	H519A	Oil filler plug ($\frac{3}{16}$ in. U.H.)	2	
29	H1842	LEFT BOTTOM MEMBER c/w CAP	1	
30	H1843	RIGHT BOTTOM MEMBER c/w CAP	1	
31	H1844	Spindle cap	2	
32	S26-3	Spring washer	4	
33	H1070	Cap bolt (1 $\frac{7}{8}$ in. U.H.)	4	
34	H1071	Drain plug	2	
35	H430	Fibre washer	4	
36	H1499	Restrictor	2	
37	H1063	Flanged bolt (23/32 in. U.H.)	2	
38	H1062	Aluminium washer	2	
39	H660	Handlebar "U" bolt	2	
40	S25-3	Plain washer	4	
41	E1310	Nut	4	

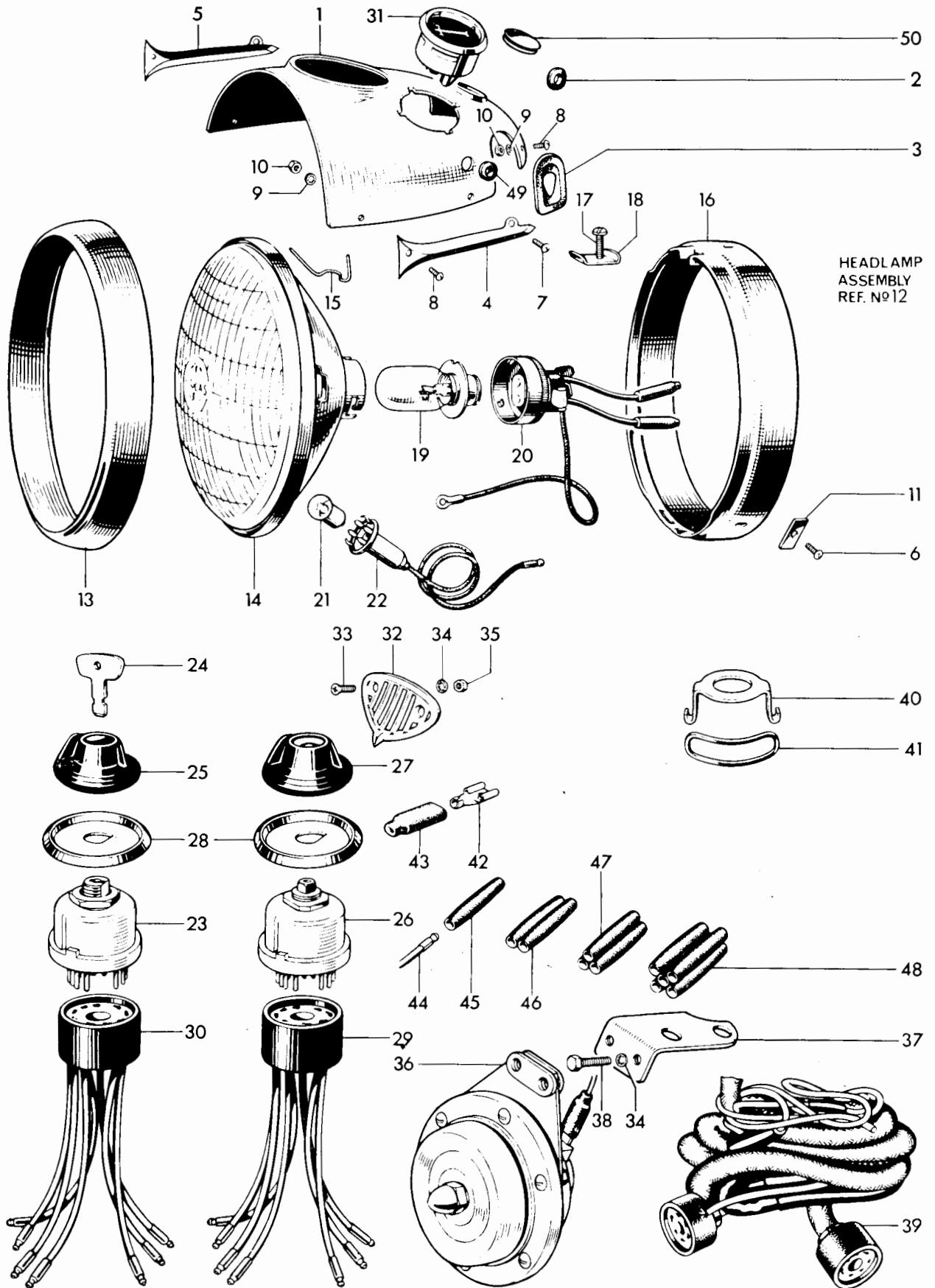

Fig. 16. NACELLE, HEADLAMP AND SWITCHES

NACELLE, HEADLAMP AND SWITCHES

1	H1781	Nacelle top	1	
2	H961	Rubber grommet	1	
3	H669	Rubber grommet	2	
4	H877	Left motif	1	
5	H878	Right motif	1	
6	H689	Screw ($\frac{1}{4}$ in. U.H.)	4	
7	H687	Screw ($\frac{3}{8}$ in. U.H.)	2	
8	H688	Screw ($\frac{5}{16}$ in. U.H.)	2	
9	E2880	Serrated washer	4	
10	H691	Nut	4	
11	H690	Nut	2	
12	59176	HEADLAMP	1	
13	553248	Rim	1	
14	516812	Light unit	1	
15	504665	Fixing wire	6	
16	553267	Fixing ring	1	
17	144921	Screw	1	
18	534296	Plate	1	
19	414	Bulb (50/40 W. L.H. Dipping. Pre-focus)	1	
20	554602	Adaptor	1	
21	222	Bulb (4W.M.C.C.)	1	
22	554710	Pilot bulbholder	1	
23	34427	IGNITION SWITCH c/w KEY, type 88SA	1	
24	54336176	Ignition key	1	
25	54336178	Ignition switch cover	1	
26	34289	Lighting switch, type 88SA	1	
27	54330934	Knob c/w screw	1	
28	54330576	Switch bezel plate	2	
29	54930007	Replacement harness socket (Lighting)	as required	
30	54930008	Replacement harness socket (Ignition)	as required	
31	36296	Ammeter, type 2AR	1	
32	H992	Horn grille	1	
33	F4129	Screw (0.435 in. U.H.)	2	
34	GS299	Serrated washer	4	
35	F3799	Nut	2	
36	H1420	Horn bracket	1	
37	70164	Horn type 8H	1	
38	F4771	Bolt ($\frac{1}{2}$ in. U.H.)	2	
39	54938942	Wiring harness	1	
40	F5983	Bracket	2	
41	F5988	Rubber band	2	
42	54942078	Lucar connector	2	
43	54190042	Insulating cover	2	
44	900269	Snap connector terminal	as required	
45	900288	Single snap connector	as required	
46	850641	Double snap connector	as required	
47	850844	Triple snap connector	as required	
48	850832	Quintuple snap connector	as required	
49	H1938	Blind grommet	2	
50	H1421	Rubber grommet	1	

FORK ASSEMBLY REF. Nº 1

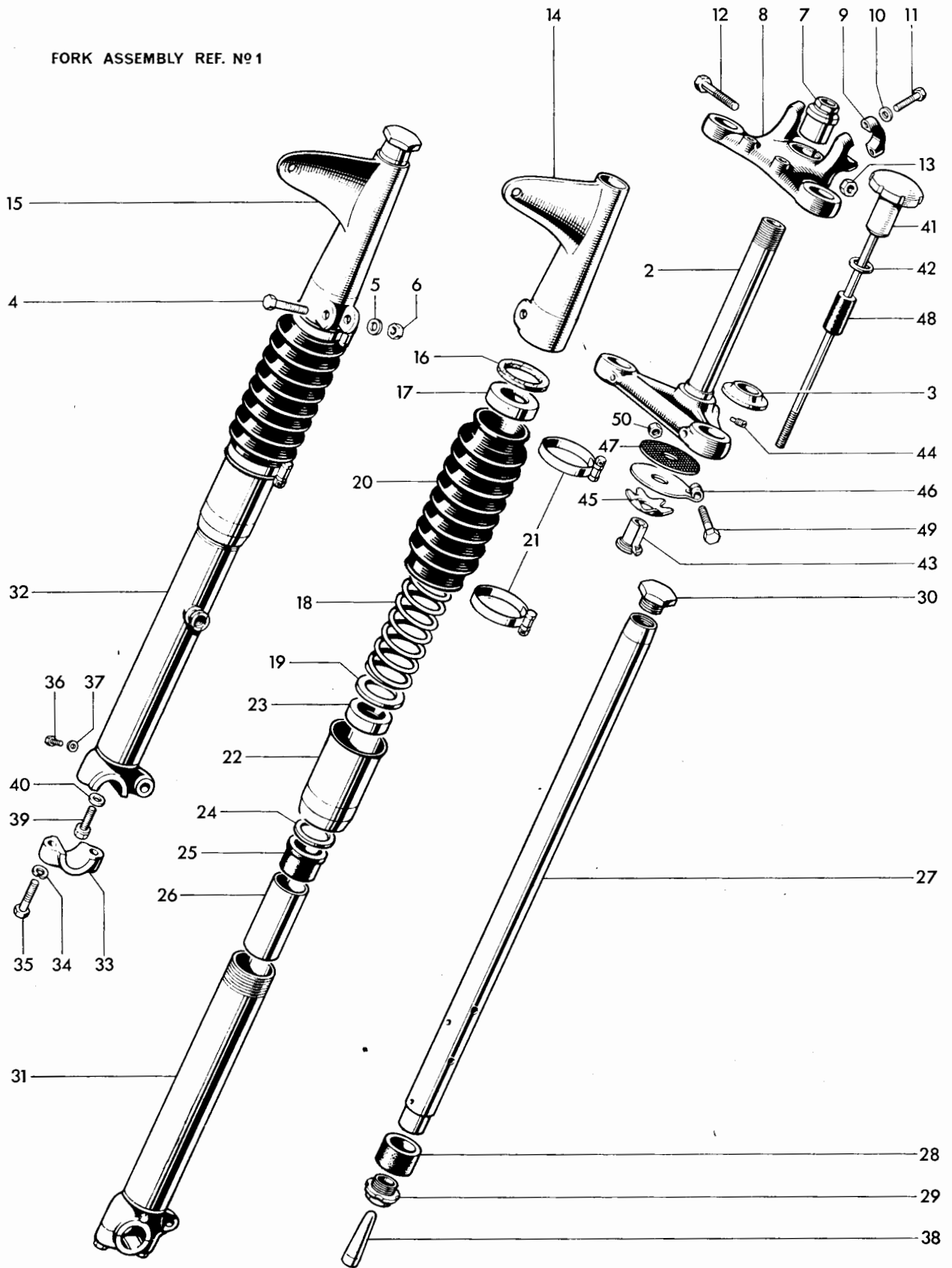

Fig. 17. TELESCOPIC FRONT FORK, T90 AND T100

TELESCOPIC FRONT FORK, T90 AND T100

Ref. No.	Part No.	Description	Quantity	Remarks
1	H1918	FORK ASSEMBLY	1	incl. U.S.A. Western T100C
2	H1328	Middle lug and stem	1	
3	H1110	Bottom cone	1	
4	H941	Pinch bolt (2 $\frac{1}{4}$ in. U.H.)	2	
5	S25-2	Plain washer	2	
6	H1335	Nut (2 $\frac{3}{8}$ in. O.A.)	2	
7	H405	Fork stem sleeve nut	1	
8	H1287	TOP LUG c/w CAPS	1	
9	H506	Handlebar cap	2	
10	S25-3	Plain washer	4	
11	H1340	Bolt (1 $\frac{1}{8}$ in. U.H.)	4	
12	F1760	Pinch bolt (1 $\frac{1}{16}$ in. U.H.)	1	
13	H379	Seated nut	1	
14	H1888	Left cover	1	
15	H1887	Right cover	1	
16	F4047	Cork washer	2	
17	H1657	Spring abutment	2	
18	H1891	Main spring (Yellow/Blue)	2	
19	H1656	Plain washer	2	
20	H1645	Telescopic gaiter	2	
21	D340	Clip	4	
22	H1654	DUST EXCLUDER SLEEVE NUT	2	
23	H1500	Oil seal	2	
24	H431	Plain washer	2	
25	H441	Top bearing	2	
26	H1896	Damping sleeve	2	
27	H1889	STANCHION c/w BEARING	2	
28	H443	Lower bearing	2	
29	H1058	Bearing nut	2	
30	H1658	Cap nut	2	
31	H1842	LEFT BOTTOM MEMBER c/w CAP	1	
32	H1843	RIGHT BOTTOM MEMBER c/w CAP	1	
33	H1844	Spindle cap	2	
34	S26-3	Spring washer	4	
35	H1070	Bolt (1 $\frac{7}{16}$ in. U.H.)	4	
36	H1071	Drain plug	2	
37	H430	Fibre washer	2	
38	H1499	Restrictor	2	
39	H1063	Flanged bolt (23/32 in. U.H.)	2	
40	H1062	Aluminium washer	2	
41	H1142	Steering damper rod	1	
42	H565	Plain washer	1	
43	H408	Adjuster sleeve	1	
44	H1286	Locating pin	1	
45	H95	Spring plate	1	
46	H1111A	Anchor plate	1	
47	H435	Friction disc	1	
48	H1618	Rubber sleeve	1	
49	F3468	Bolt (2 $\frac{1}{4}$ in. U.H.)	1	
50	S1-51	Nut	1	

FORK ASSEMBLY REF. Nº 1

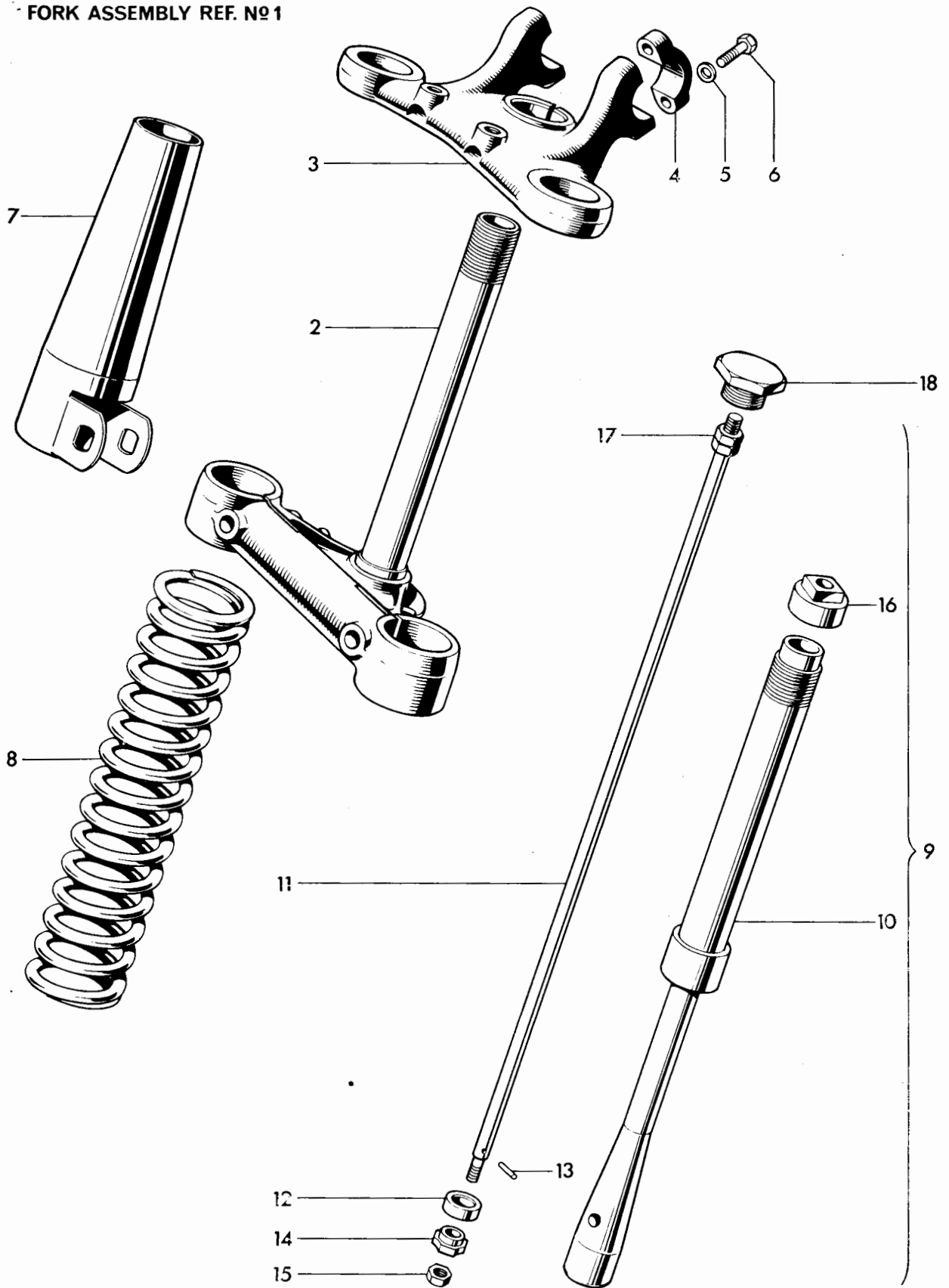

Fig. 18. TELESCOPIC FRONT FORK, U.S.A. EASTERN T100C

TELESCOPIC FRONT FORK, U.S.A. EASTERN T100C

Ref. No.	Part No.	Description	Quantity	Remarks
1	H2015	FORK ASSEMBLY	1	
2	H1328	Middle lug and stem...	1	
3	H1287	TOP LUG c/w CAPS	1	
4	H506	Cap	2	
5	S25-3	Plain washer	4	
6	H1340	Bolt (1 $\frac{1}{8}$ in. U.H.)	4	
7	H1696	Top cover	As required	
8	H1892	Main spring (yellow/green)	2	
9	H1913	DAMPER ASSEMBLY	2	
10	H1893	Restrictor body...	2	
11	H1897	Rod	2	
12	H1764	Cup	2	
13	H454	Pin	2	
14	H452	Oil restrictor	2	
15	F879	Nut	2	
16	H1761	Restrictor body cap	2	
17	T224	Nut	4	
18	H1762	Cap nut	2	

All other parts as page 53.

ASSEMBLY REF. No. 1

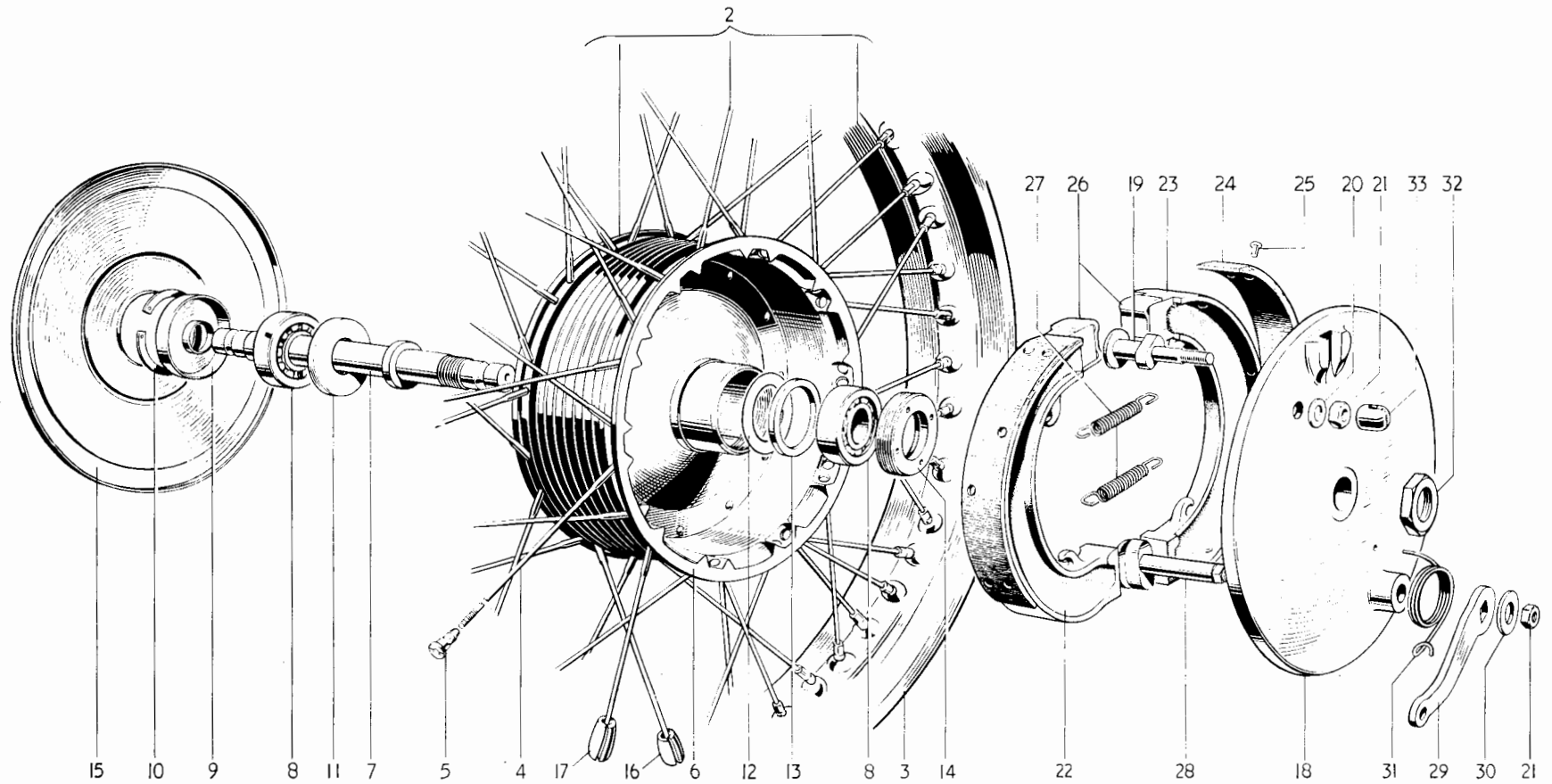

Fig. 19. FRONT WHEEL

FRONT WHEEL

Ref. No.	Part No.	Description	Quantity	Remarks
1	W1665	FRONT WHEEL COMPLETE	1	T100R, T100C
1	W1664	FRONT WHEEL COMPLETE	1	
2	W1229	RIM, SPOKES AND HUB ASSEMBLY	1	T100R, T100C
2	W1370	RIM, SPOKES AND HUB ASSEMBLY	1	
3	W1230	Front wheel rim (WM2-19)	1	T100R, T100C
3	W1373	Front wheel rim (WM2-18)	1	
4	W1236	Spoke (8/10G x 6 in. straight) c/w nipple	40	T100R, T100C
4	W1497	Spoke (8/10G x 5 $\frac{5}{8}$ in. straight) c/w nipple	40	
5	S79-2	Spoke nipple	40	
6	W1231	Hub and brake drum	1	
7	W1641	Wheel spindle	1	
8	W653	Bearing	2	
9	W1237	Dust cover	1	
10	T280	Circlip	1	
11	W1481	Grease retainer	1	
12	W1474	Grease retainer (Brake side)	1	
13	W1238	Backing ring	1	
14	W582	Retaining ring	1	
15	W1334	Cover plate	1	
16	W1197	Balance weight, $\frac{1}{2}$ oz.	as required	
17	W1198	Balance weight, 1 oz.	as required	
18	W1301	Brake anchor plate	1	
19	W1639	Fulcrum pin	1	
20	S25-2	Plain washer	1	
21	S1-52	Nut	2	
22	W1406	LEADING BRAKE SHOE C/W LINING	1	
23	W1407	TRAILING BRAKE SHOE C/W LINING	1	
24	NW243	Brake lining	2	
25	W129	Brass rivet	16	
26	W1415	Thrust pad	2	
27	W135	Shoe return spring	2	
28	W1243	Brake cam	1	
29	W1331	Brake cam lever	1	
30	S25-6	Plain washer	1	
31	W592	Lever return spring	1	
32	W1246	Anchor plate nut	1	
33	W1640	Abutment ($\frac{9}{16}$ in. deep)	as required	
33	W1711	Abutment ($\frac{13}{16}$ in. deep)	as required	

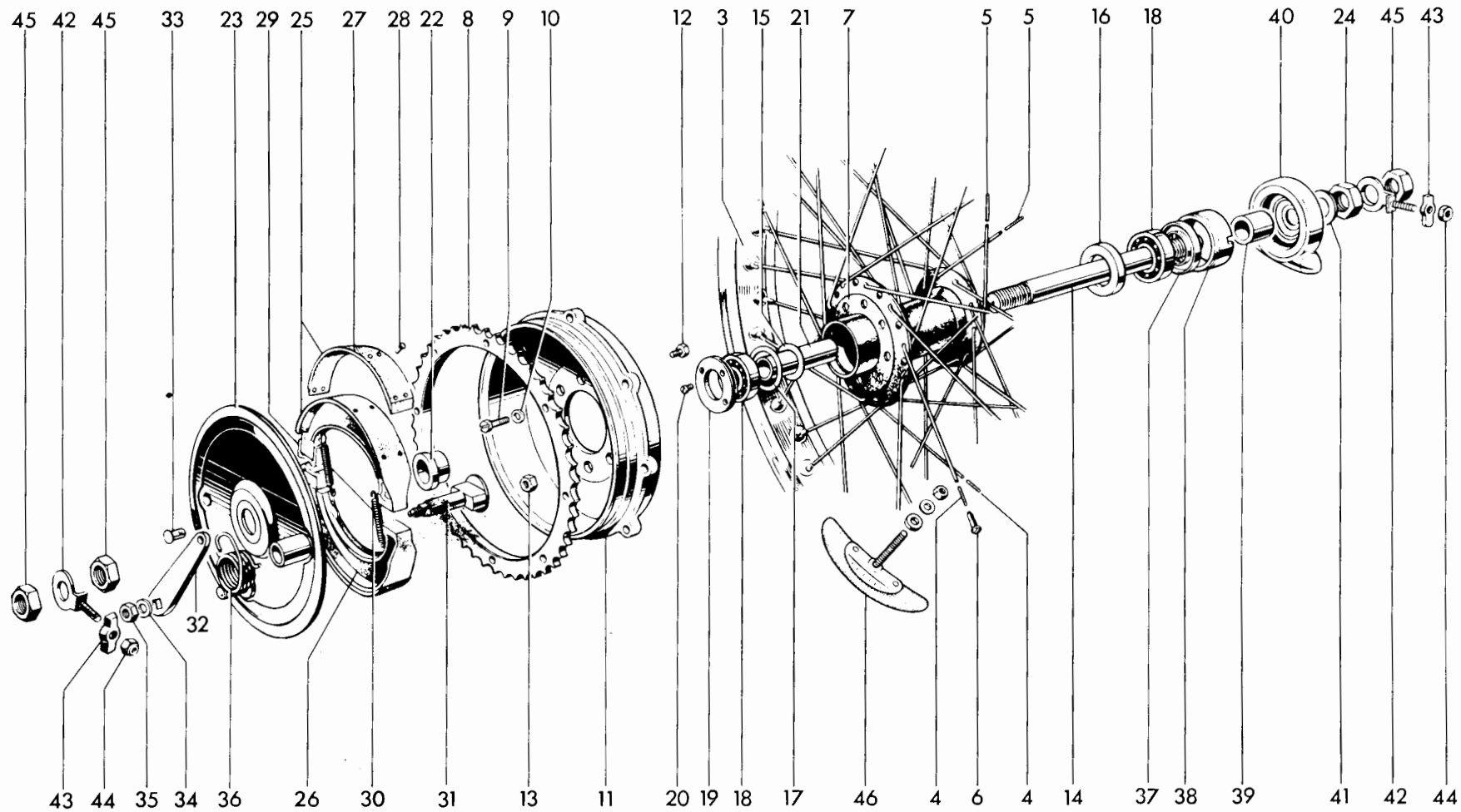

Fig. 20. REAR WHEEL

REAR WHEEL

Ref. No.	Part No.	Description	Quantity	Remarks
1	W1741	REAR WHEEL COMPLETE	1	
1	W1742	REAR WHEEL COMPLETE	1	T100R, T100C
2	W1470	RIM, SPOKES AND HUB ASSEMBLY	1	
2	W1486	RIM, SPOKES AND HUB ASSEMBLY	1	T100R, T100C
3	W1471	Rear wheel rim WM2-18	1	
3	W1007	Rear wheel rim WM3-18	1	T100R, T100C
4	W1107	Spoke (8/10G x 7 $\frac{3}{16}$ in. 90°) c/w nipple	20	
5	W1108	Spoke (8/10G x 7 $\frac{7}{8}$ in. 90°) c/w nipple	20	
6	S79-2	Spoke nipple	40	
7	W1472	Hub	1	
8	W1499	Sprocket, 46T	1	
9	W1500	Bolt	8	
10	E1612	Serrated washer	8	
11	W1498	Brake drum	1	
12	W1690	Bolt ($\frac{1}{8}$ in. U.H.)	8	
13	W1691	Self locking nut	8	
14	W1281	Wheel spindle	1	
15	W1474	Grease retainer (brake side)	1	
16	W1654	Grease retainer	1	
17	W1022	Backing ring	1	
18	W653	Bearing	2	
19	W1021	RETAINING RING	1	
20	W1710	Locking screw ($\frac{5}{16}$ in. U.H.)	1	
21	W1278	Distance tube	1	
22	W1024	Distance piece	1	
23	W1112	Brake anchor plate	1	
24	W1282	Nut	1	
25	W1406	LEADING BRAKE SHOE C/W LINING	1	
26	W1407	TRAILING BRAKE SHOE C/W LINING	1	
27	NW243	Brake lining	2	
28	W129	Brass rivet	16	
29	W1415	Thrust pad	2	
30	W135	Shoe return spring	2	
31	W1083	Brake cam	1	
32	W1466	Brake cam lever	1	
33	W1467	Pivot pin...	1	
34	S25-6	Plain washer	1	
35	S1-52	Nut	1	
36	W1090	Lever return spring	1	
37	W1635	Grease retainer	1	
38	W1476	Speedometer adaptor	1	
39	W1477	Distance piece	1	
40	D373	Speedometer gearbox	1	
41	W1280	Plain washer	1	
42	W1134	Chain adjuster	2	
43	W1015	Adjuster end plate	2	
44	W1058	Self-locking nut	2	
45	F1747	Spindle nut	3	
46	D106	Tyre security bolt...	2	
46	WM3	Tyre security bolt...	2	T100R, T100C

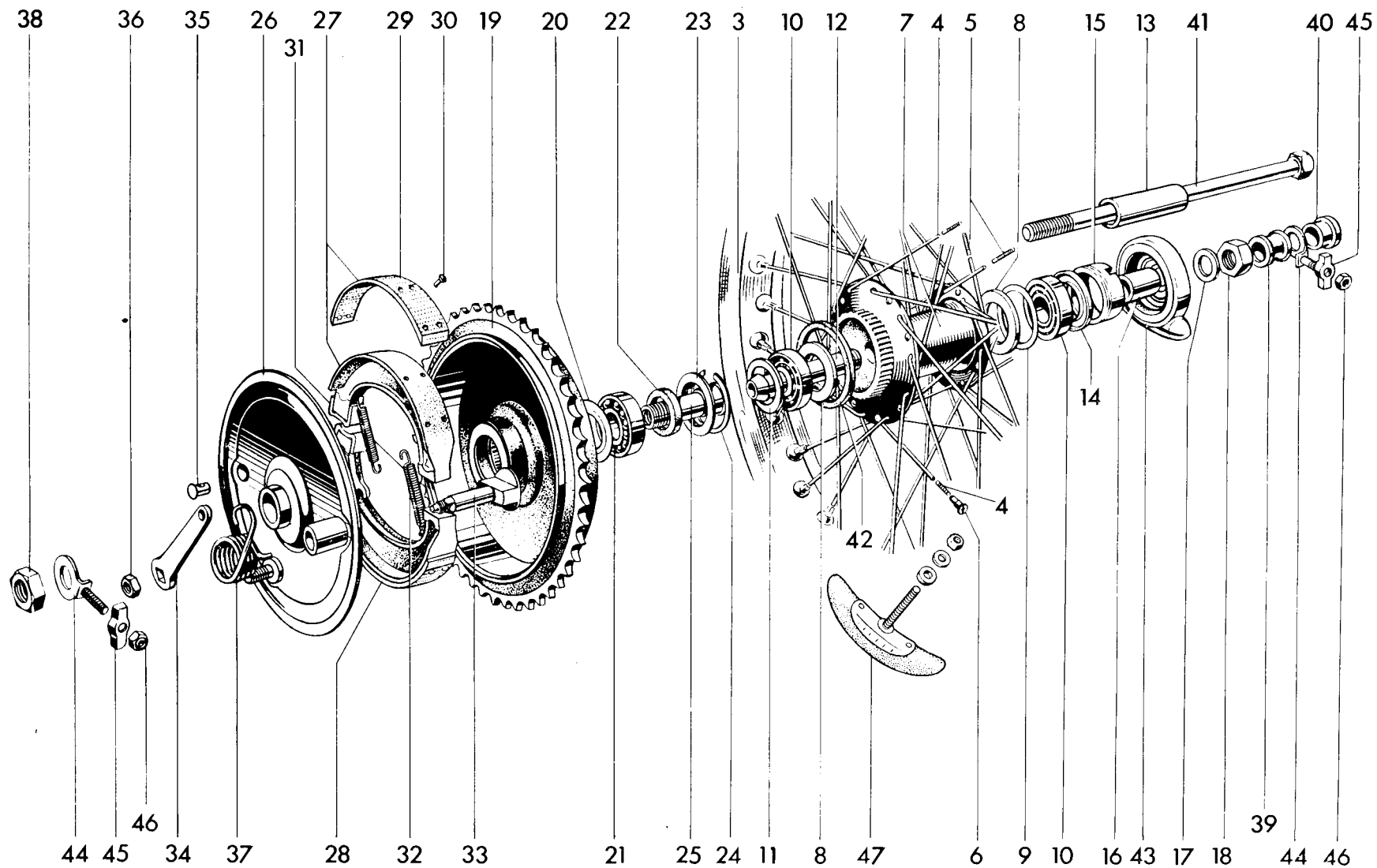

Fig. 21. QUICKLY DETACHABLE REAR WHEEL (NOT U.S.A.)

QUICKLY DETACHABLE REAR WHEEL (NOT U.S.A.)

Ref. No.	Part No.	DESCRIPTION	QUANTITY	REMARKS
1	W1746	Q.D. REAR WHEEL COMPLETE	1	
1	W1745	Q.D. REAR WHEEL COMPLETE	1	T100R, T100C
2	W1747	RIM, SPOKES AND HUB ASSEMBLY	1	
2	W1603	RIM, SPOKES AND HUB ASSEMBLY	1	T100R, T100C
3	W1471	Rear wheel rim WM2-18	1	
3	W1007	Rear wheel rim WM3-18	1	T100R, T100C
4	W1107	Spoke (8/10G x 7 ⁷ / ₈ in.90°) c/w nipple	20	
5	W1108	Spoke (8/10G x 7 ⁷ / ₈ in.90°) c/w nipple	20	
6	S79-2	Spoke nipple	40	
7	W1593	Hub	1	
8	W1595	Grease retainer	2	
9	W1509	Backing ring	2	
10	S35-7	Bearing	2	
11	W1596	Dust cap	1	
12	W1614	Bearing sleeve	1	
13	W1598	Distance piece (inner)	2	
14	W1635	Grease retainer	1	
15	W1599	Speedometer adaptor	1	
16	W1477	Distance piece (outer)	1	
17	W1280	Plain washer	1	
18	W1282	Nut	1	
19	W1040	Sprocket and brake drum 46T	1	
20	W1143	Grease retainer	1	
21	W1041	Bearing	1	
22	W1042	Felt washer	1	
23	W1043	Bearing and felt retainer	1	
24	W1044	Circlip	1	
25	W1045	Bearing sleeve	1	
26	W1121	Brake anchor plate	1	
27	W1406	LEADING BRAKE SHOE C/W LINING	1	
28	W1407	TRAILING BRAKE SHOE C/W LINING	1	
29	NW243	Brake lining	2	
30	W129	Brass rivet	16	
31	W1415	Thrust pad	2	
32	W135	Shoe return spring	2	
33	W1083	Brake cam	1	
34	W1466	Brake cam lever	1	
35	W1467	Pivot pin	1	
36	S1-52	Nut	1	
37	W1090	Lever return spring	1	
38	W1052	Nut	1	
39	W1392	Inner distance piece	1	
40	W1170	Outer distance piece	1	
41	W1055	Spindle	1	
42	W1091	Rubber sealing ring	1	
43	D373	Speedometer gearbox	1	
44	W1135	Chain adjuster	2	
45	W1015	Adjuster end plate	2	
46	W1058	Self-locking nut	2	
47	D106	Tyre security bolt	2	
47	WM3	Tyre security bolt	2	T100R, T100C

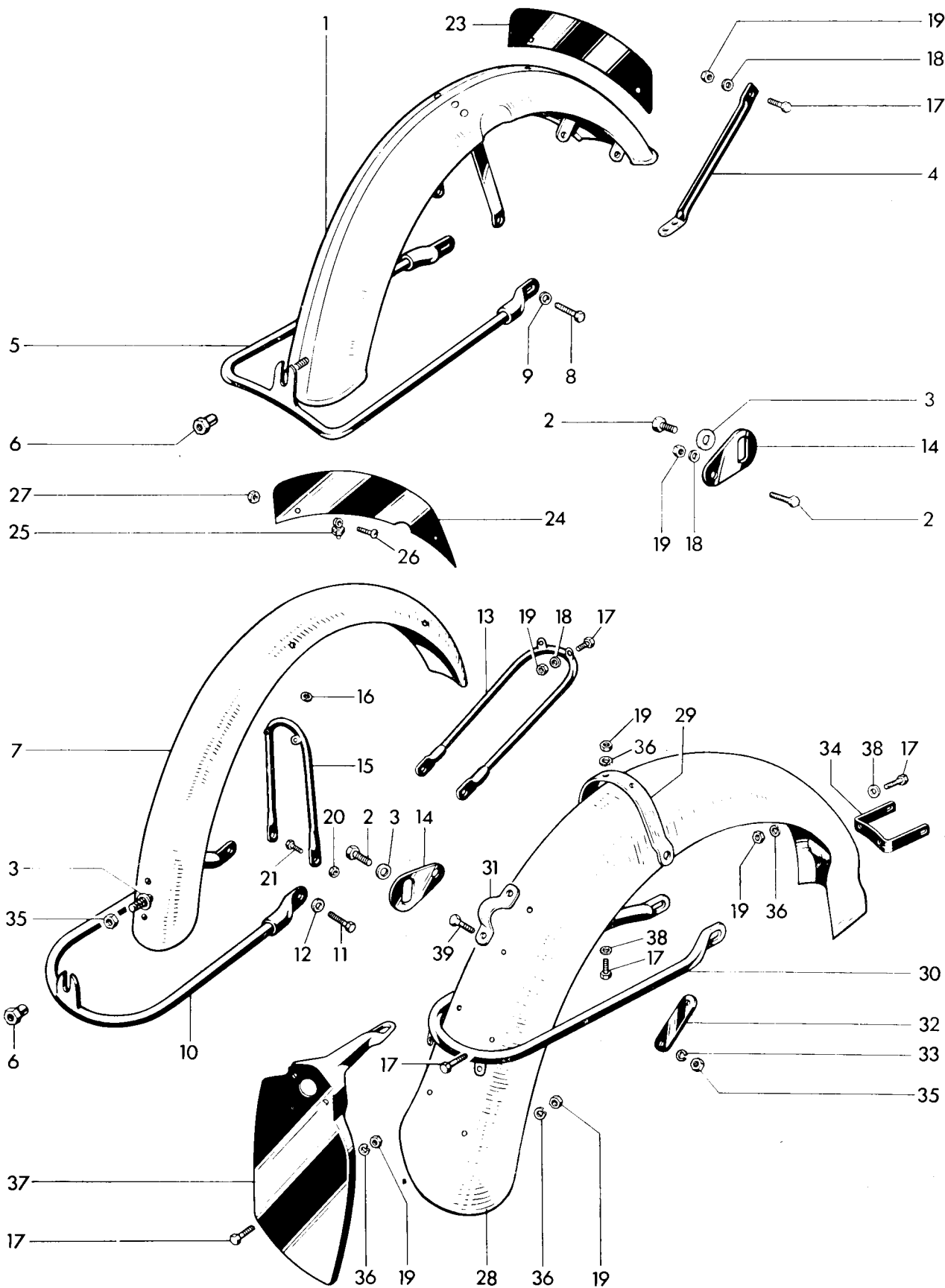

Fig. 22. MUDGUARDS (STANDARD)

MUDGUARDS (STANDARD)

Ref. No.	Part No.	DESCRIPTION	QUANTITY	REMARKS
1	H1901	Front mudguard	1	3TA, 5TA
2	F929	Bolt ($\frac{1}{2}$ in. U.H.)	5	
3	F4299	Plain washer	4	
4	H1964	Front stay	2	
5	H1100	Bottom stay	1	3TA, 5TA
6	NS362	Spigot nut	1	
7	H1675	Mudguard blade	1	T90, T100
8	W62	Bolt	2	3TA, 5TA
9	S25-2	Plain washer	2	3TA, 5TA
10	H1482	Bottom stay	1	
11	H424	Bolt ($\frac{39}{64}$ in. U.H.)	2	} T90, T100
12	S25-71	Plain washer	2	
13	H1681	Front stay	1	
14	H1685	Bracket	2	
15	H1683	Mudguard bridge	1	T90, T100
16	WE170	Fibre washer	2	
17	DS57	Bolt ($\frac{7}{16}$ in. U.H.)	10	
18	S25-1	Plain washer	6	
19	F879	Nut	17	
20	T224	Nut	2	T90, T100
21	DS55	Bolt ($\frac{15}{16}$ in. U.H.)	2	T90, T100
22	F1369	Bolt ($\frac{5}{8}$ in. U.H.)	2	3TA, 5TA
23	F6469	Number plate	1	3TA, 5TA
24	F6470	Number plate	1	T90, T100
25	H741	Clip assembly	2	
26	H687	Screw ($\frac{3}{8}$ in. U.H.)... ..	2	
27	H745	Nut	2	
28	F5984	Mudguard blade	1	
29	F6915	Mudguard bridge	1	
30	F5424	Lifting handle	1	
31	F5994	Clip	1	
32	F6031	Backing plate	1	
33	S26-3	Spring washer	9	
34	F6916	Bracket	1	
35	S1-51	Nut	3	
36	S26-2	Spring washer	10	
37	F5924	Number plate	1	
38	F6310	Plain washer	4	
39	H590	Bolt ($\frac{9}{16}$ in. U.H.)... ..	2	

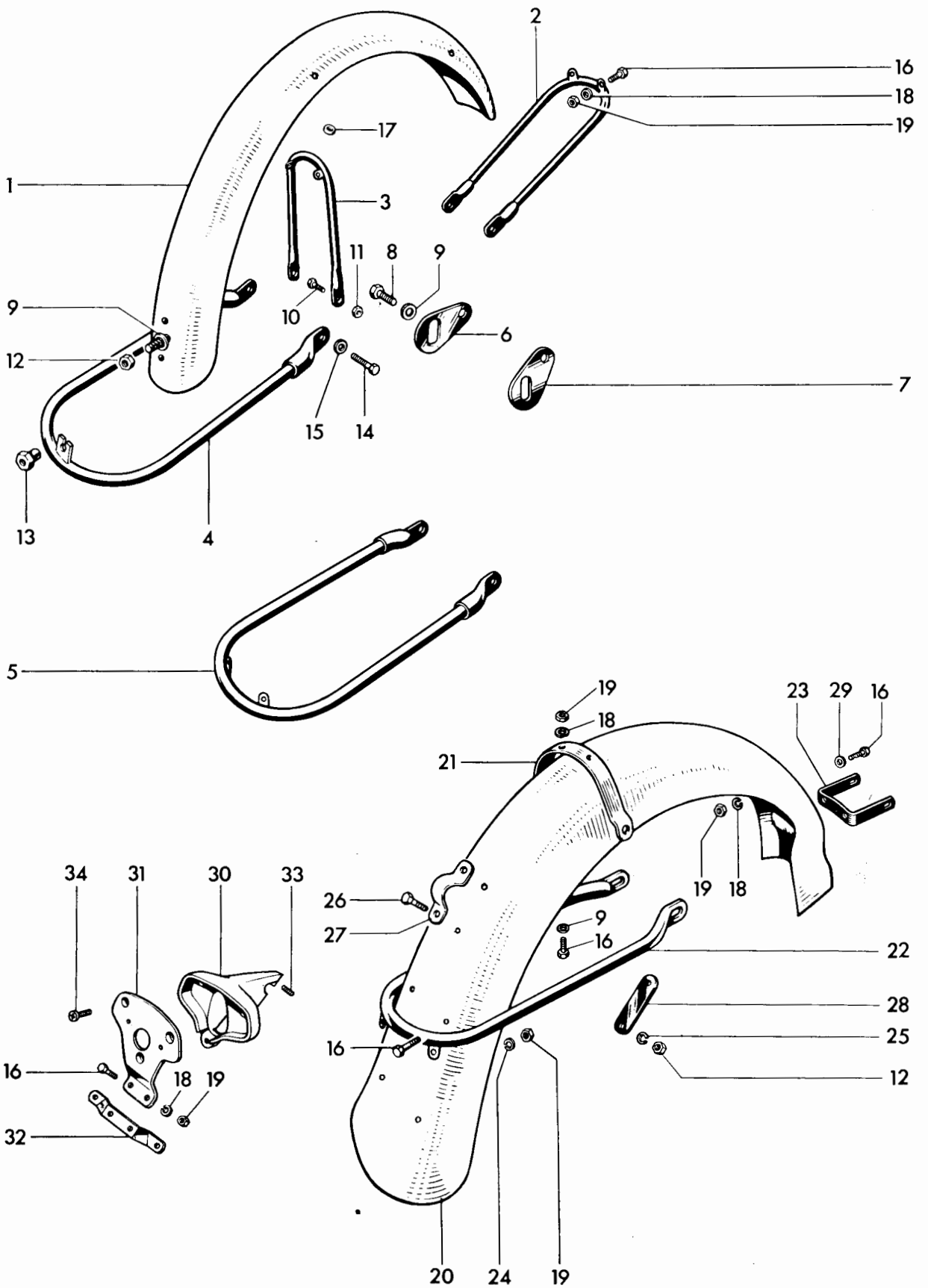

Fig. 23. FENDERS (U.S.A.)

FENDERS (U.S.A.)

Ref. No.	Part No.	Description	Quantity	Remarks
1	H1677	Front fender	1	T100R, Eastern T100C
1	H1687	Front fender (aluminium)	1	Western T100C
2	H1681	Front stay	1	
3	H1683	Centre bridge	1	
4	H1678	Bottom stay	1	T100R, Eastern T100C
5	H1273	Bottom stay	1	Western T100C
6	H1685	Bracket	2	
7	H1688	Bracket	2	Western T100C
8	F929	Bolt ($\frac{1}{2}$ in. U.H.)	5	
9	F4299	Plain washer	5	
10	DS55	Bolt ($\frac{5}{16}$ in. U.H.)	2	
11	T224	Nut	2	
12	S1-51	Nut	4	
13	NS362	Spigot nut	1	
14	H424	Bolt	2	
15	S25-71	Plain washer	2	
16	DS57	Bolt ($\frac{7}{16}$ in. U.H.)	10	
17	WE170	Fibre washer	4	
18	S25-1	Plain washer	13	
19	F879	Nut	13	
20	F6965	Rear fender	1	T100R, Eastern T100C
20	F6966	Rear fender (aluminium)	1	Western T100C
21	F6915	Fender bridge	1	
22	F5424	Lifting handle	1	
23	F6916	Bracket	1	
24	S26-2	Spring washer	2	
25	S26-3	Spring washer	5	
26	H590	Bolt ($\frac{9}{16}$ in. U.H.)	2	
27	F5994	Clip	1	
28	F6031	Backing place	1	
29	F6310	Plain washer	1	
30	F6847	Tail lamp adapter	1	
31	F6849	Tail lamp plate	1	
32	F6850	Number plate bracket	1	
33	E2980	Stud ($\frac{15}{16}$ in. O.A.)	1	
34	F4715	Screw ($\frac{13}{32}$ in. U.H.)	3	

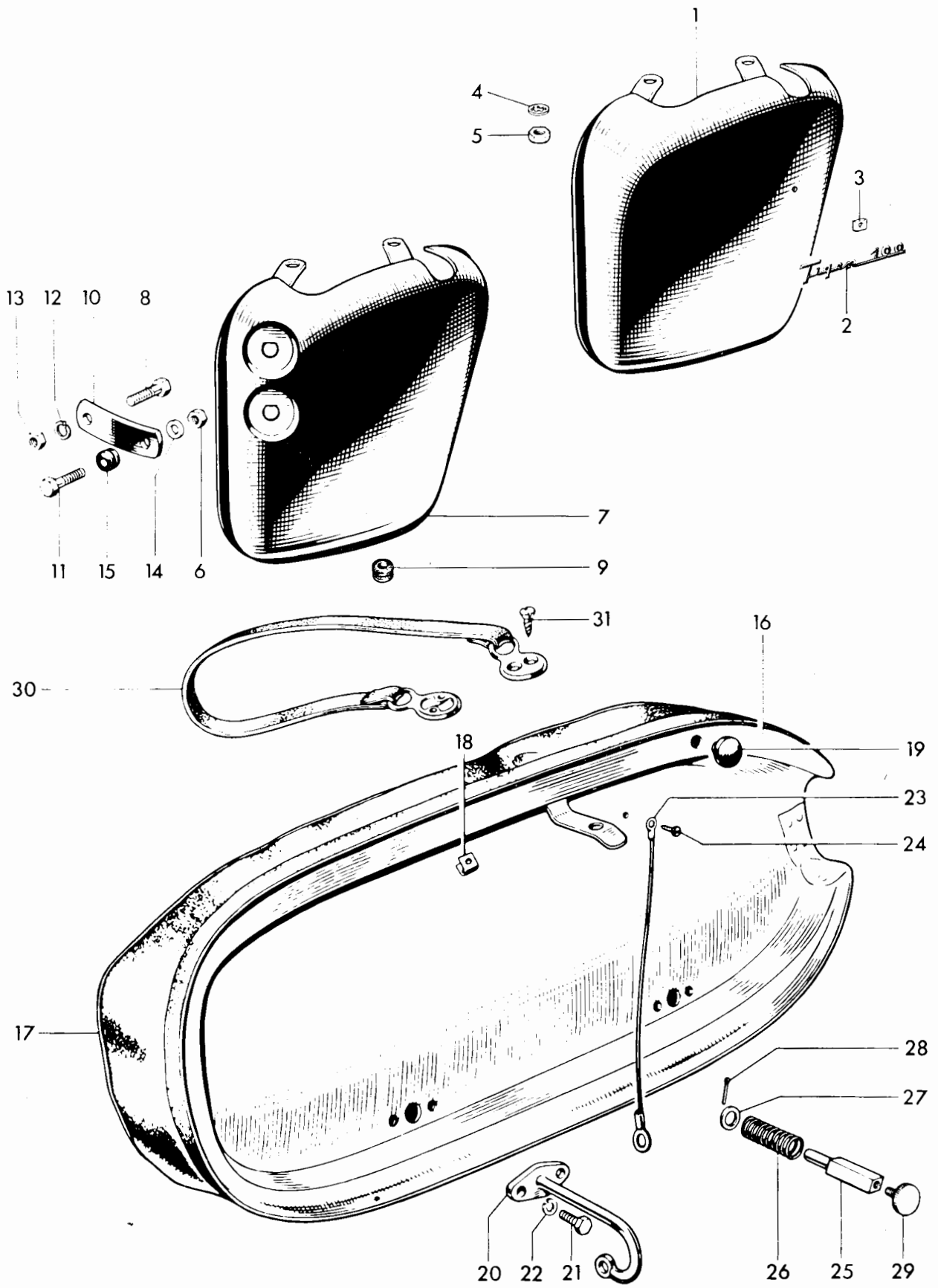

Fig. 24. PANELS AND TWINSEAT

PANELS AND TWINSEAT

1	F6964	Left panel	1	3TA, 5TA
2	F6947	Motif "Twenty-One"	2	
2	F6948	Motif "Tiger 90"	2	
2	F6949	Motif "Tiger 100"	2	
2	F6950	Motif "Speed Twin"	2	
3	F4317	Spire nut	4	
4	E1612	Serrated washer	2	
5	13104/00/2	Nut	2	
6	15104/00/2	Self-locking nut	1	
7	F6931	Switch panel	1	T90, T100
8	F1369	Bolt ($\frac{5}{8}$ in. U.H.)	1	
9	F5466	Grommet	2	
10	F5976	Link	1	
11	11104/06/2	Bolt ($\frac{3}{4}$ in. U.H.)	1	
12	S26-2	Spring washer	1	
13	F879	Nut	1	
14	S25-43	Washer	1	
15	H961	Grommet	3	
16	F4239	TWINSEAT (GREY TOP)	1	
16	F4360A	TWINSEAT (BLACK TOP)	1	Eastern T100C
17	F4244	Twin seat cover c/w clips (GREY TOP)	1	
17	F4244A	Twinseat cover c/w clips (BLACK TOP)	1	Eastern T100C
18	F4475	Clip		As required
19	F4898	Rubber buffer	2	
20	F4222	Hinge	2	
21	DS57	Bolt ($\frac{7}{8}$ in. U.H.)	4	
22	S26-2	Spring washer	4	
23	D374	Check wire	1	
24	F4483	Self tapping screw	1	
25	F4226	Seat catch plunger	1	
26	F4228	Spring	1	
27	E1719A	Plain washer	1	
28	$\frac{3}{32}$ in. x $\frac{1}{2}$ in.	Split pin	1	
29	F6659	Knob	1	
30	F4361	Safety strap	1	Western T100C,T100R
31	F4365	Self tapping screw	4	

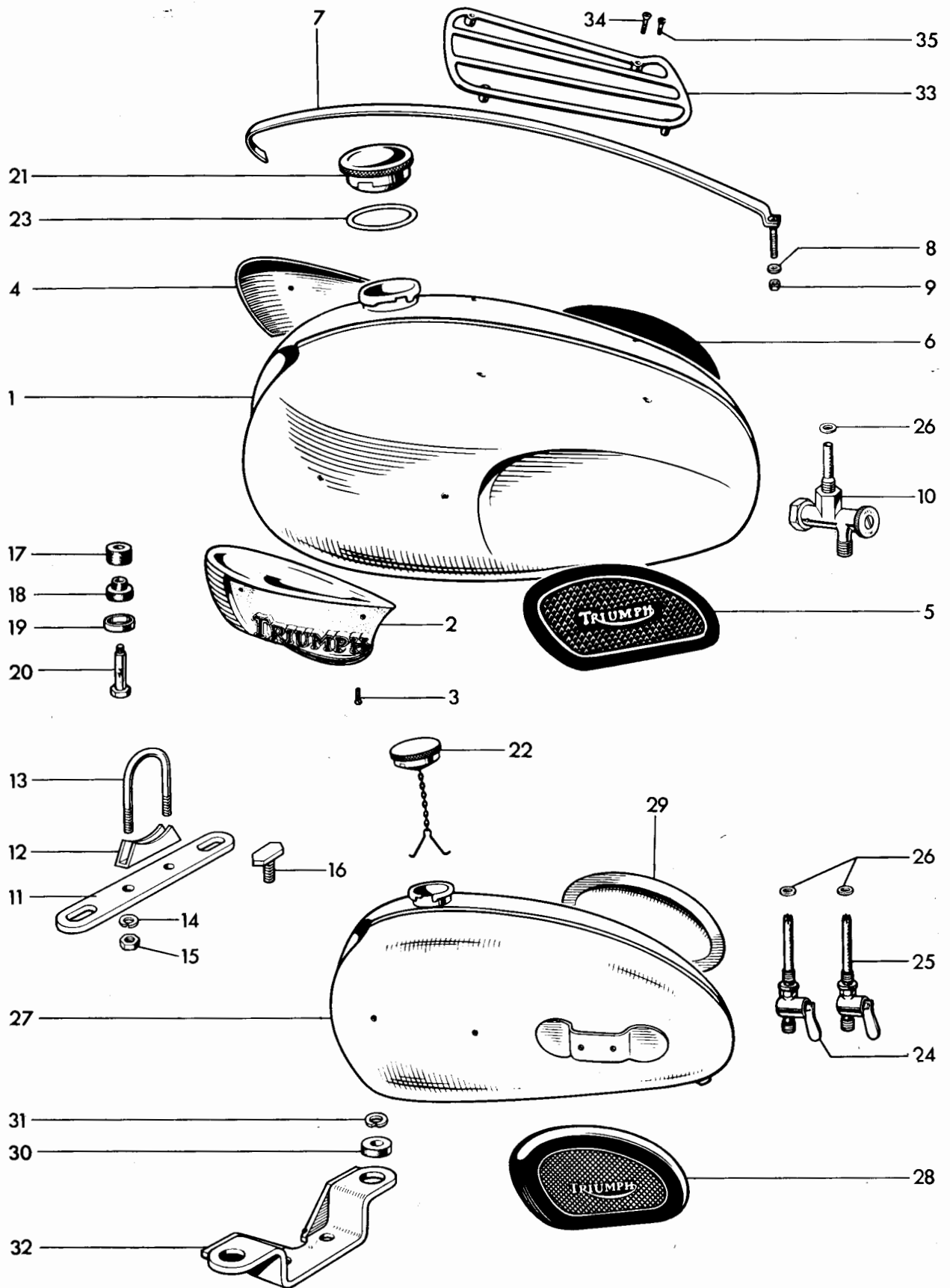

Fig. 25. PETROL TANK

PETROL (GAS) TANKS

Ref. No.	Part No.	DESCRIPTION	QUANTITY	REMARKS
1	F7001	Petrol tank (3 gallons)	1	} 3TA, 5TA T90, T100
2	F6887	Styling unit (left)	1	
3	F4129	Styling unit screw (0.435 in. U.H.)	4	
4	F6888	Styling unit (right)	1	
5	F5401	Left knee grip	1	
6	F5402	Right knee grip	1	
7	F6313	Centre styling strip	1	
8	F4019	Serrated washer	1	
9	H919	Nut	1	
10	F1717	Petrol tap	1	
11	F6143	Tank bracket	2	} 3TA, 5TA, T90, T100
12	F6144	Saddle	1	
13	F6145	'U' bolt	1	
14	S26-3	Spring washer	4	
15	S1-51	Nut	4	
16	F6535	'T' head bolt	2	
17	F5228	Rubber washer	4	
18	F5229	Spigot rubber	4	
19	F3814	Cup	4	
20	F1808	Bolt	4	
21	F3220	FILLER CAP	1	} T100C, T100R
22	F3219	FILLER CAP c/w JACK CHAIN	1	
23	F4048	Joint washer	1	
24	F4971	Petrol tap (left)	1	
25	F4972	Petrol tap with reserve tube	1	
26	F1511	Fibre washer	2	
27	F7002	Petrol tank (2½ U.S. gallons)	1	
28	F1606	Left knee grip	1	
29	F1605	Right knee grip	1	
30	F4108	Rubber washer	4	
31	S26-2	Spring washer	4	
32	F6958	Tank bracket	2	
33	F3917	Parcel grid	1	
34	F2936	Screw	1	
35	F4384	Rubber blanking plug	A	

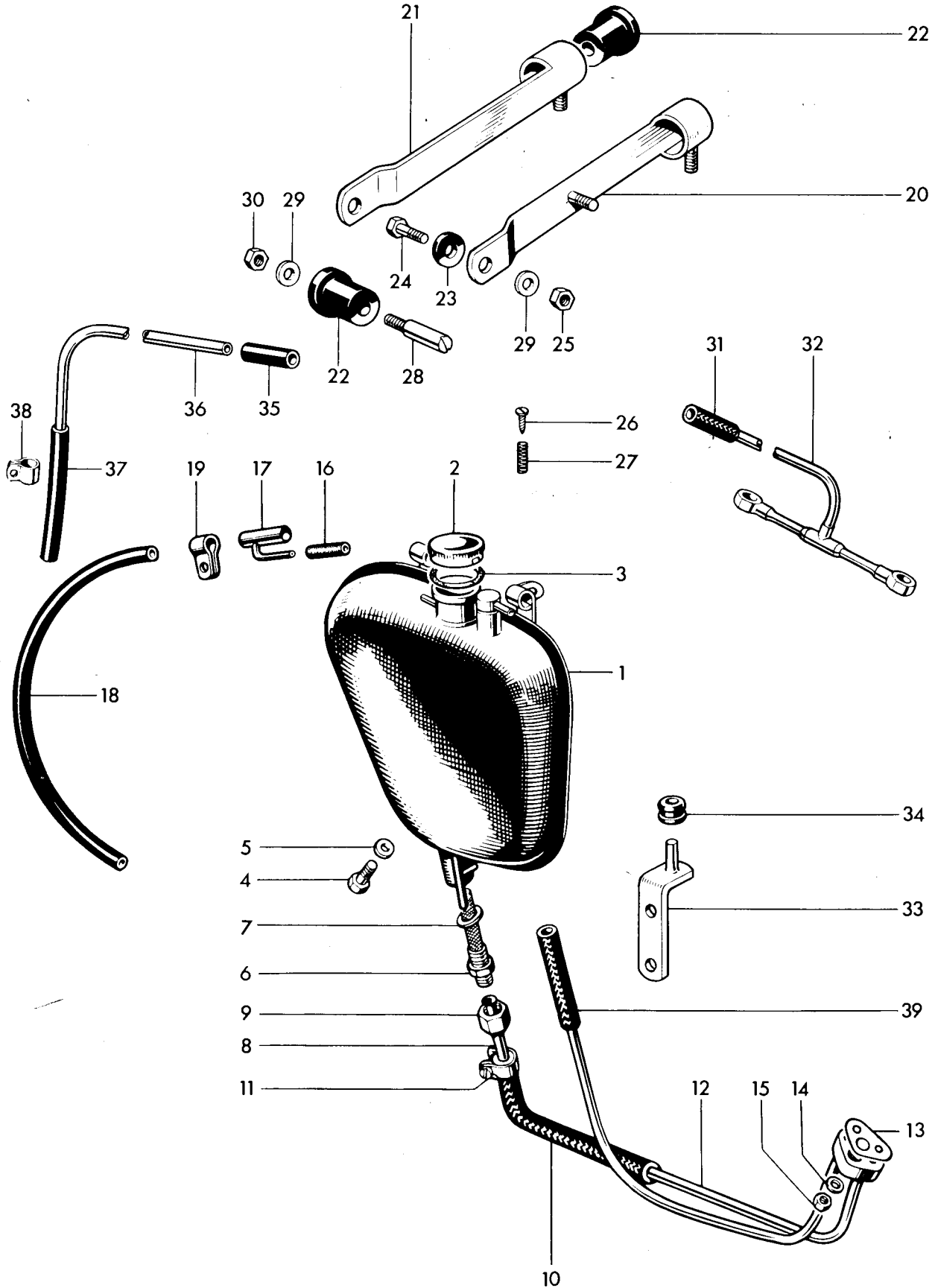

Fig. 26. OIL TANK

OIL TANK

1	F6877	Oil tank	1	
2	F3216A	FILLER CAP	1	
3	F4047	Joint washer	1	
4	F5343	Drain plug	1	
5	PT104B	Fibre washer	1	
6	F3179	Oil tank filter	1	
7	F1713	Fibre washer	1	
8	F6103	Upper feed pipe	1	
9	F3182	Union nut	1	
10	E3353	Flexible connector, long	2	
11	E5473	Clip	4	
12	E5434	Oil pipes and junction block	1	
13	E3763	Joint washer	1	
14	E3446	Plain washer	1	
15	E1310	Nut	1	
16	E6356	Vent pipe	1	
17	E5370	"T" piece	1	
18	E5376	Extension pipe	1	
18	E5376	Extension pipe	1	
19	F3098	Clip	2	
20	F6892	Front strap	1	
21	*F6894	Rear strap	1	
22	F6673	Spigot rubber	4	
23	F6968	Rubber washer	2	
24	11104/06/2	Bolt ($\frac{3}{4}$ in. U.H.)	2	
25	15104/00/2	Self locking nut	2	
26	F6511	Metering screw	1	
27	F6874	Coil spring	1	
28	F6672	Screwed peg	2	
29	S25-13	Plain washer	4	
30	F879	Nut	2	
31	E6353	Rubber connector	1	
32	E6351	Rocker oil feed pipe	1	
33	F6898	Bracket	1	
34	F6039	Grommet	1	
35	E6355	Flexible pipe	1	
36	E6354	Chain oiler pipe	1	
37	E6357	Flexible pipe	1	
38	F6970	Clip	1	
39	MF119	Flexible connector, short	1	

* See page 73

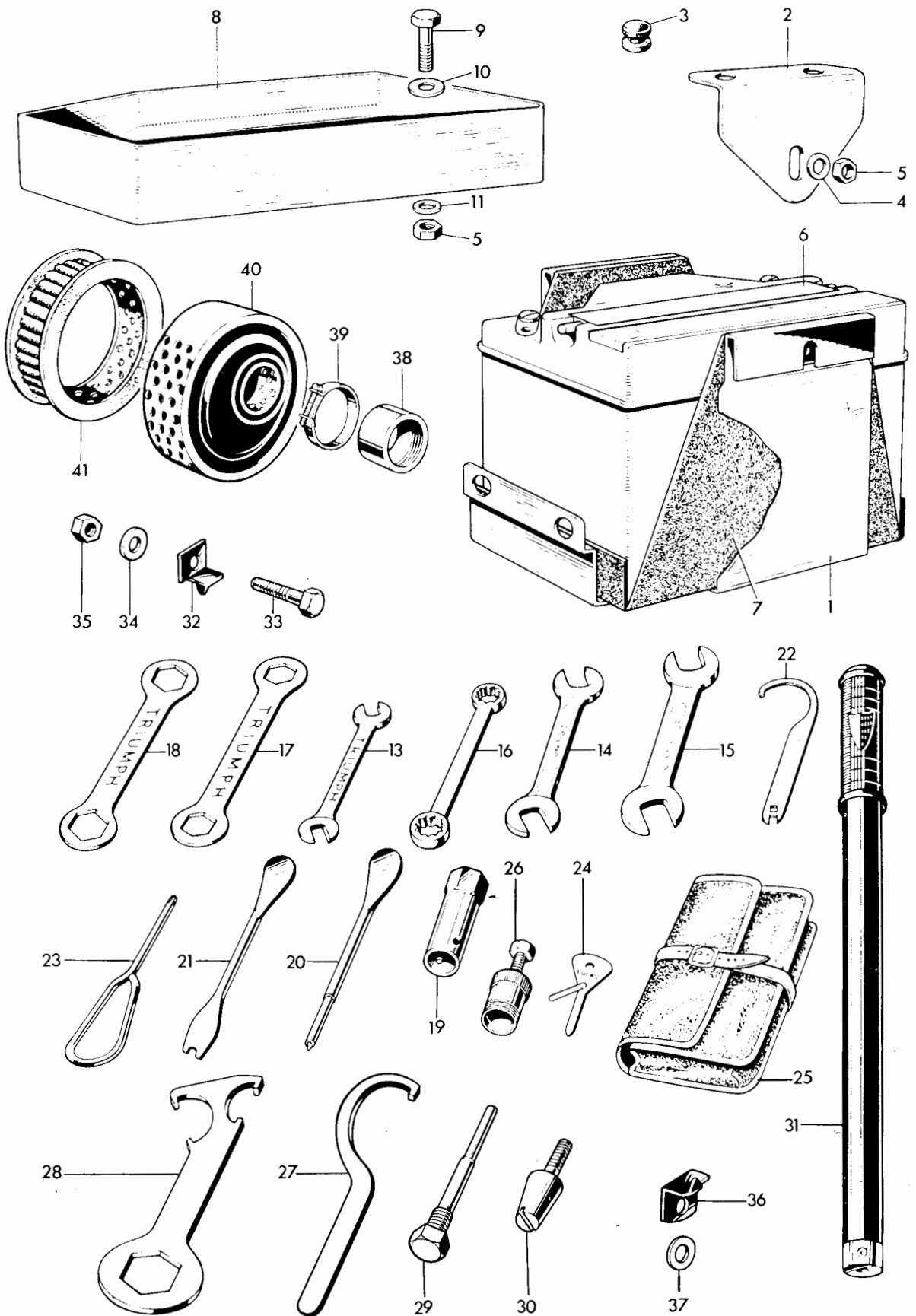

Fig. 27. BATTERY, TOOLKIT AND AIR FILTER

BATTERY, TOOLKIT AND AIR FILTER

1	*F6891	Battery carrier	1	
2	*F6897	Retainer	2	
3	*E6226	Rubber	4	
4	S25-1	Plain washer	3	
5	F879	Nut	4	
6	*PUZ5A	Battery	1	
7	*F6969	Battery carrier lining	1	
8	F6901	Tool tray	1	
9	F1369	Bolt ($\frac{5}{8}$ in. U.H.)	2	
10	F7128	Plain washer	2	
11	S25-13	Plain washer	1	
12	D446	TOOL KIT	1	
13	D360	Open spanner, $\frac{1}{8}$ in. x $\frac{5}{32}$ in. whit.	1	
14	NA55	Open spanner, $\frac{1}{4}$ in. x $\frac{5}{16}$ in. whit.	1	
15	DA16	Open spanner, $\frac{3}{8}$ in. x $\frac{7}{16}$ in. whit.	1	
16	D370	Ring spanner, $\frac{7}{16}$ in. x $\frac{1}{4}$ in. whit.	1	
17	PA57	Ring spanner, $\frac{1}{2}$ in. x $\frac{7}{16}$ in. whit.	1	
18	D311	Ring spanner, $\frac{5}{8}$ in. x $\frac{1}{16}$ in. whit.	1	
19	D87	Box spanner, spark plug	1	
20	D363	Tyre lever and tommy bar	1	
21	D364	Tyre lever and clutch key	1	
22	D362	"C" spanner and tappet key	1	
23	D336	Phillips No. 3 screwdriver	1	
24	400935	Ignition screwdriver and feeler gauge	1	
25	WA58	Tool roll	1	
26	DA50/1	Clutch hub extractor	as required	
27	D527	Fork spanner (for sleeve nut)	as required	
28	D220	Fork spanner (for cap nut)	as required	
29	D484	Contact breaker extractor	as required	
30	D486	Contact breaker assembly pilot	as required	
31	D296	Tyre inflator	1	
32	F5432	Inflator top bracket	1	
33	F1369	Bolt ($\frac{5}{8}$ in. U.H.)	1	
34	S25-43	Plain washer	1	
35	S1-40	Nut	1	
36	F5433	Inflator bottom bracket	1	
37	S25-3	Plain washer	1	
38	E5194	Adaptor	1	3TA, 5TA
38	F4812	Adaptor	4	T90, T100
39	F5625	Clip	1	
40	F6430	AIR FILTER	1	
41	F4811	Filter element (felt)	1	
40	F6433	AIR FILTER	1	U.S.A. models
41	F5694	Filter element (paper)	1	U.S.A. models

*Some early models have two 6 volt batteries. These are interchangeable as a group but the following part numbers apply to this condition (Not Illustrated)

PUZ5A	Battery	use MKZ9E (2 off)
F6891	Battery carrier	use F7083
F6894	Rear strap	use F7086
F6897	Retainer	use F7085 (1 off)
E6226	Rubber	use F7045 (3 off)
—	Rubber (between batteries)	use F7046 (2 off)
F6969	Battery carrier lining	use F7087

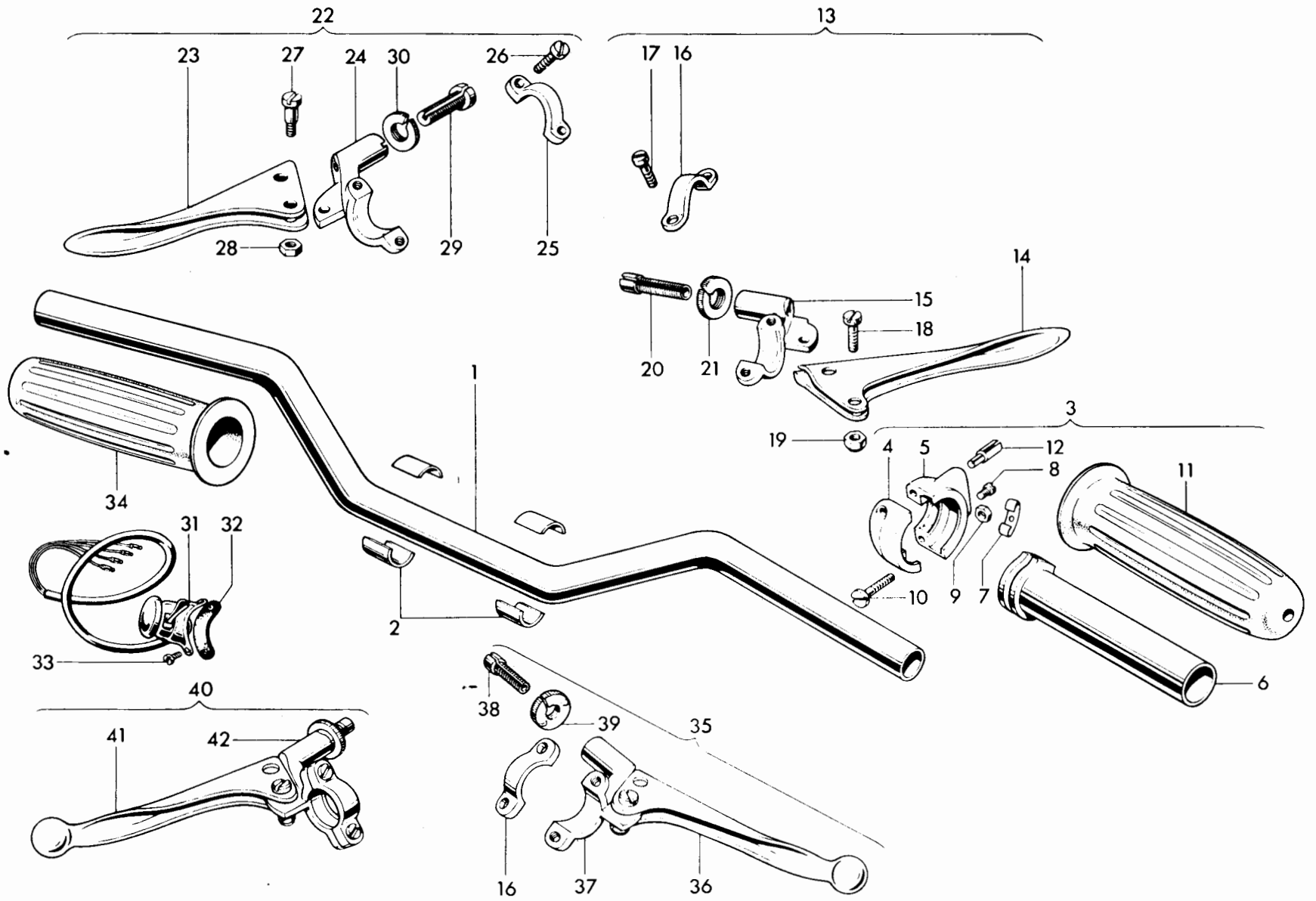
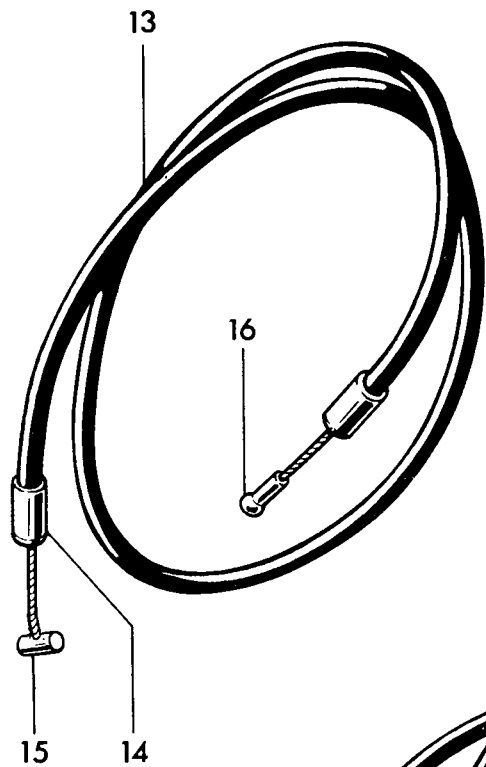

Fig. 28. HANDLEBARS AND CONTROL LEVERS

HANDLEBARS AND CONTROL LEVERS

Ref. No.	Part No.	Description	Quantity	Remarks
1	H1871	Handlebar	1	3TA, 5TA
1	H1872	Handlebar	1	T90, T100
1	H1519	American handlebar	1	T100C
1	H1873	American handlebar	1	T100R
2	H1425	Packing piece	4	
3	16/362	TWISTGRIP	1	
4	16/328	Body top half	1	
5	16/329	Body bottom half	1	
6	16/091	Rotor	1	
7	16/008	Friction spring	1	
8	16/009	Friction spring screw	1	
9	16/010	Nut	1	
10	11/014	Screw	2	
11	366/012	Handlebar grip	1	
12	16/011	Cable stop	1	
13	18/999	FRONT BRAKE LEVER ASSEMBLY	1	
14	18/535	Brake lever	1	
15	18/1013	Brake lever bracket	1	
16	12/595	Clamp	1	
17	11/014	Screw	2	
18	18/087	Fulcrum screw	1	
19	18/053	Self-locking nut	1	
20	18/1005	Cable adjuster	1	
21	18/1006	Thumb nut	1	
22	18/1000	CLUTCH LEVER ASSEMBLY	1	
23	18/528	Clutch lever	1	
24	18/1009	Clutch lever bracket	1	
25	12/595	Clamp	1	
26	11/014	Screw	2	
27	18/087	Fulcrum screw	1	
28	18/053	Self-locking nut	1	
29	18/1005	Cable adjuster	1	
30	18/1006	Thumb nut	1	
31	31563	Horn push and dip switch	1	
32	380459	Backing rubber	1	
33	H1876	Screw (½ in. U.H.)	2	
34	366/011	Handlebar grip	1	
35	18/951	FRONT BRAKE LEVER ASSEMBLY (Ball-end)	1	} T100C, T100R
36	18/754	Brake lever (Ball-end)	1	
37	18/777	Brake lever bracket	1	
38	18/838	Cable adjuster	1	
39	18/839	Thumb nut	1	
40	18/952	CLUTCH LEVER ASSEMBLY (Ball-end)	1	
41	18/752	Clutch lever (Ball-end)	1	
42	18/773	Clutch lever bracket	1	



CLUTCH
CABLE

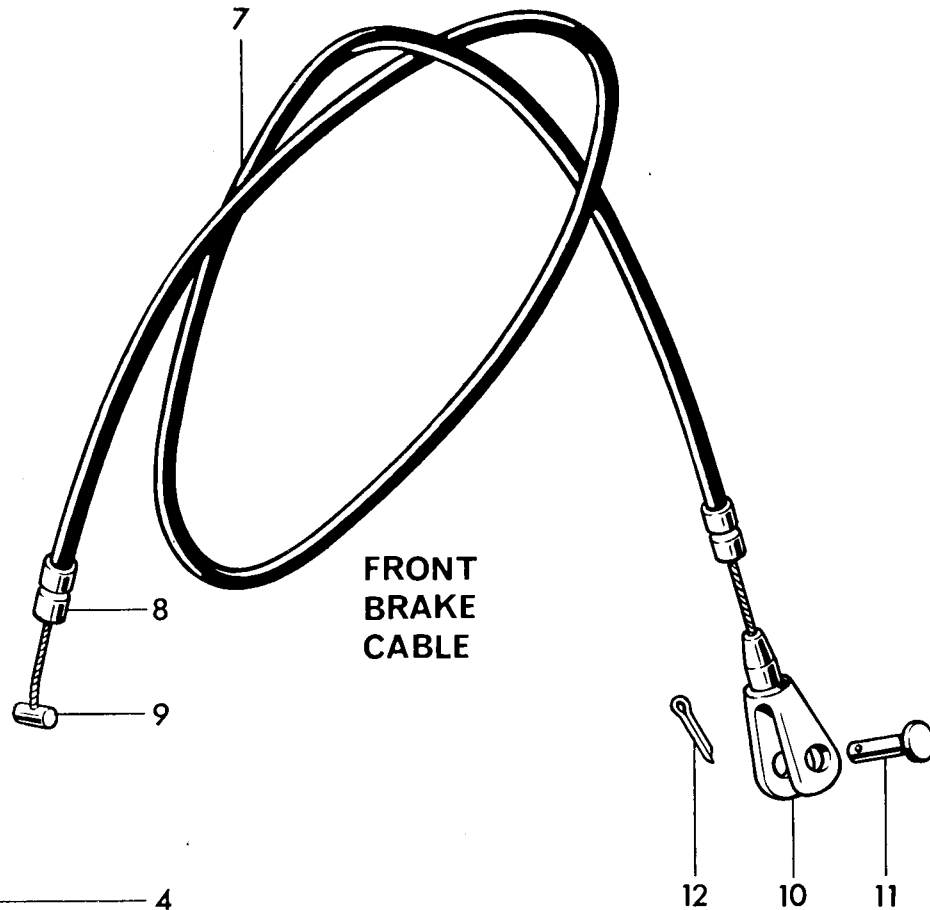

FRONT
BRAKE
CABLE

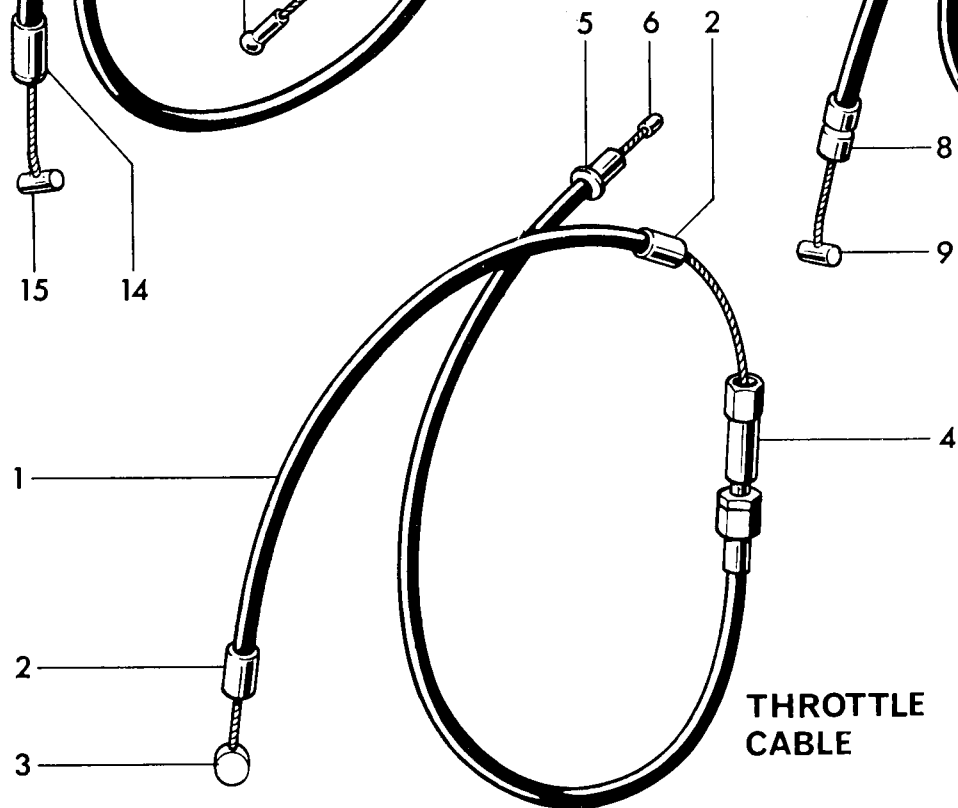

THROTTLE
CABLE

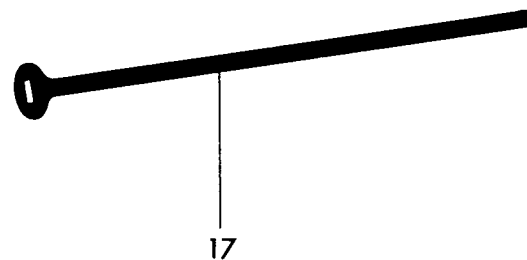

Fig. 29. CONTROL CABLES

CONTROL CABLES

Ref. No.	Part. No.	DESCRIPTION	QUANTITY	REMARKS
1	D495	THROTTLE CABLE	1	
2	D101	Ferrule	3	
3	D83	Nipple	1	
4	D104	Adjuster	1	
5	6/132A	Ferrule	1	
6	NS191	Nipple	1	
7	D561	FRONT BRAKE CABLE	1	3TA, 5TA
7	D560	FRONT BRAKE CABLE	1	T90, T100
8	D103	Ferrule	2	
9	D506	Nipple	1	
10	W593	Fork end	1	
11	WF32	Pivot pin... ..	1	
12	$\frac{1}{8}$ in. x $\frac{3}{8}$ in.	Split pin	1	
13	D566	CLUTCH CABLE	1	
13	D565	AMERICAN CLUTCH CABLE	1	T100R, T100C
14	D103	Ferrule	2	
15	D506	Nipple	1	
16	DS73	Nipple	1	
17	XA69	Cable clip	As required	

CARBURETTER COMPLETE REF. No. 1

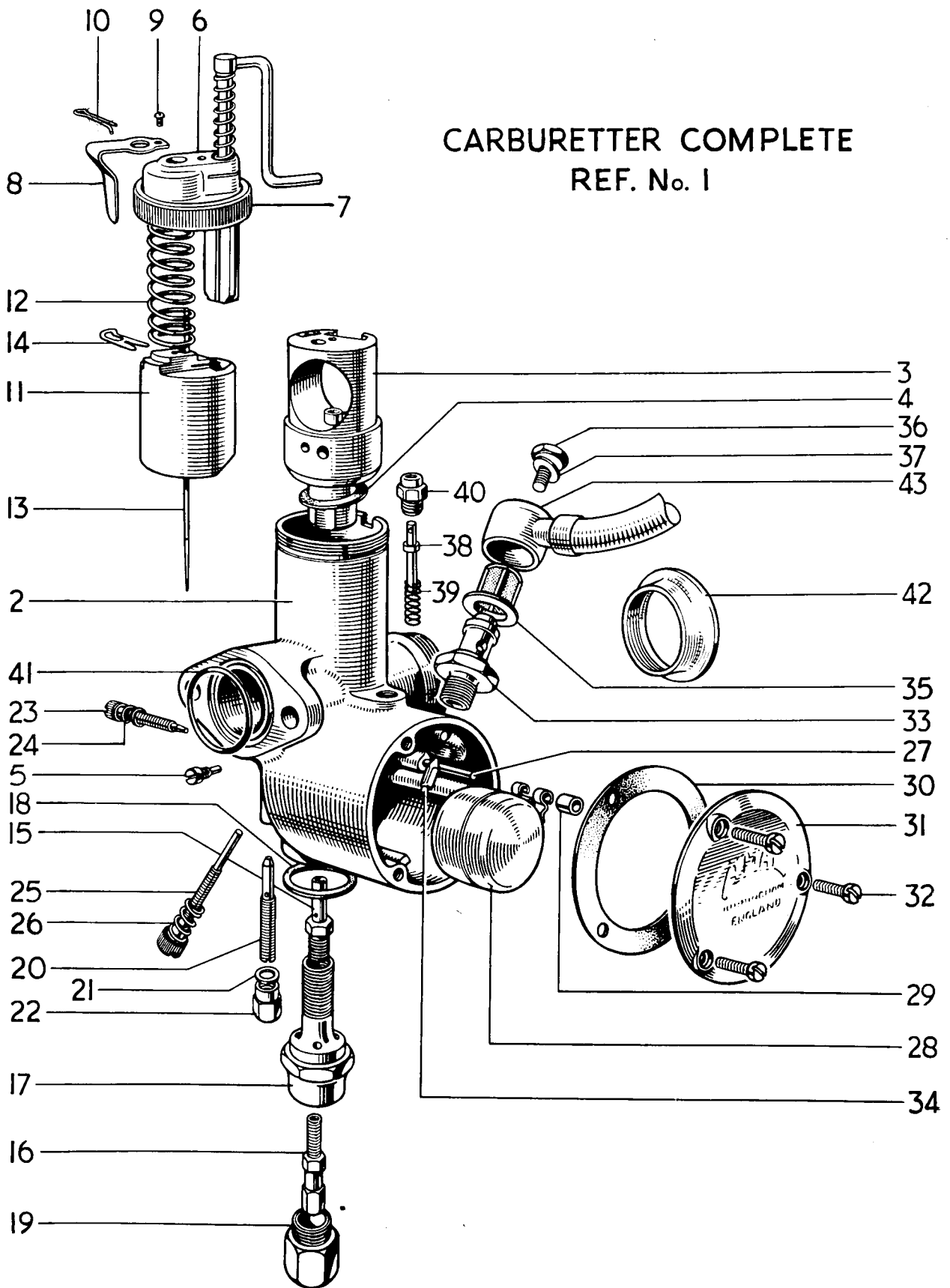

Fig. 30. CARBURETTER, 3TA AND 5TA

CARBURETTER, 3TA AND 5TA

Ref. No.	Part No.	DESCRIPTION	QUANTITY	REMARKS
1	375/62	CARBURETTER, 25/32 in. choke	1	3TA
1	375/35	CARBURETTER, $\frac{7}{8}$ in. choke	1	5TA
2	375/003	Mixing chamber, 25/32 in. choke	1	3TA
2	375/005	Mixing chamber, $\frac{7}{8}$ in. choke	1	5TA
3	375/057	Jet block, 25/32 in. choke	1	3TA
3	375/059	Jet block, $\frac{7}{8}$ in. choke	1	5TA
4	375/067	Joint washer	1	
5	376/070	Peg screw	1	
6	375/102	AIR VALVE ASSEMBLY	1	
7	375/065	Mixing chamber cap	1	
8	375/071	Spring	1	
9	4/241	Screw	1	
10	30/064	Spring	1	
11	375/060	Throttle valve ($3\frac{1}{2}$ cutaway)	1	3TA
11	375/060	Throttle valve (3 cutaway)	1	5TA
12	375/079	Throttle return spring	1	
13	375/063	Needle (Type B)	1	
14	4/230	Needle clip	1	
15	376/072	Needle jet (.106)	1	
16	376/100	Main jet (100)	1	3TA
16	376/100	Main jet (160)	1	5TA
17	376/073	Jet holder	1	
18	376/074	Fibre washer	1	
19	376/075	Cover nut	1	
20	376/076	Pilot jet (25)	1	
21	116/162	Fibre washer	1	
22	376/095	Cover nut	1	
23	332/017	Air adjusting screw	1	
24	4/148	Spring	1	
25	376/068	Throttle stop screw	1	
26	376/069	Spring	1	
27	376/085	Float spindle	1	
28	376/083	Float	1	
29	376/094	Bush	1	
30	376/078	Joint washer	1	
31	376/077	Cover	1	
32	376/079	Screw	3	
33	376/088	Needle seating	1	
34	376/089	Needle	1	
35	376/093	Filter	1	
36	376/091	Bolt	1	
37	376/092	Fibre washer	1	
38	376/086	Tickler	1	
39	376/087	Spring	1	
40	343/011	Tickler body	1	
41	244/765	"O" ring seal... ..	1	
42	229/048	Air intake tube		As required
43	F4308	Petrol pipe	1	

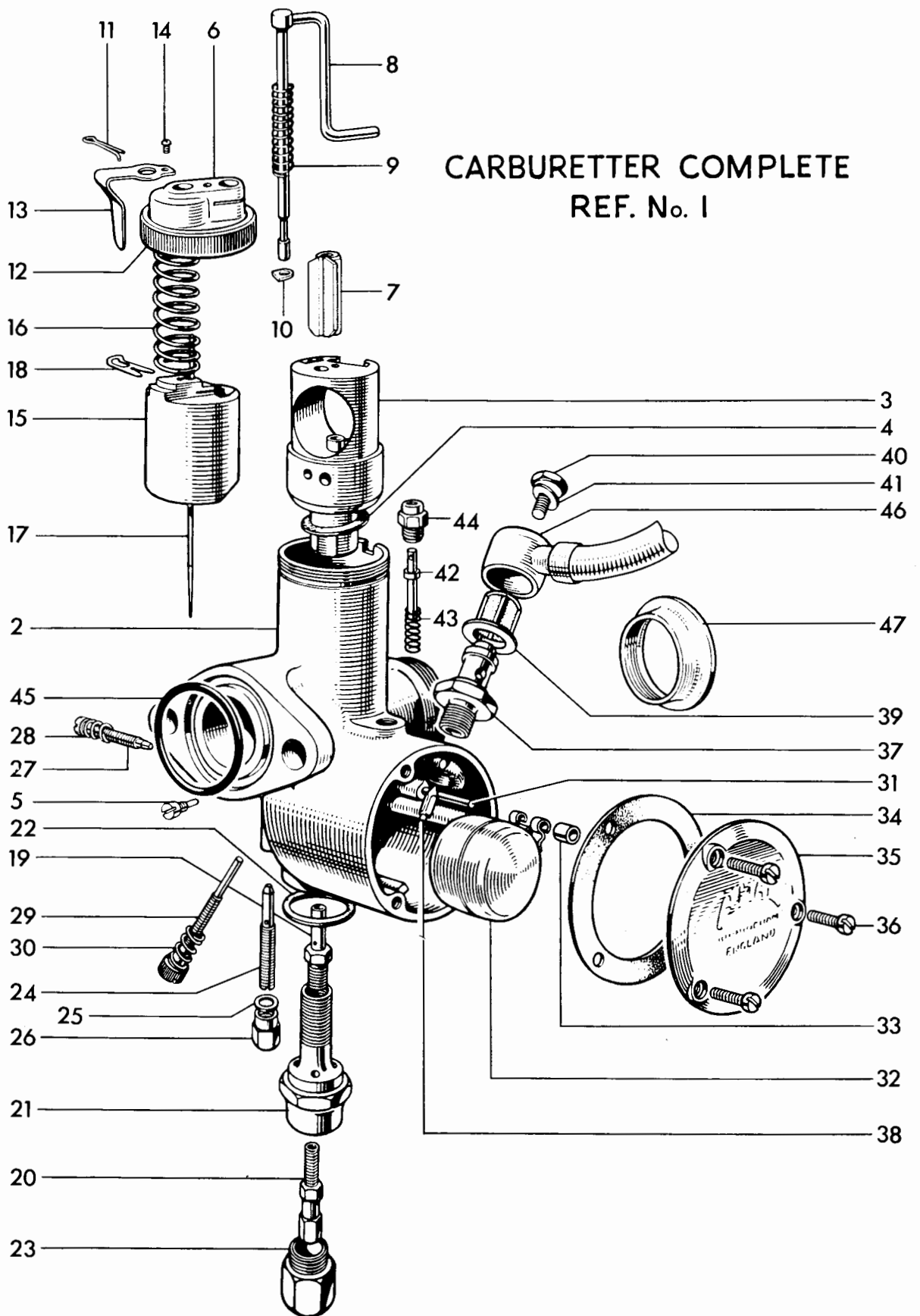

Fig. 31. . CARBURETTER, T90 AND T100

CARBURETTER, T90 AND T100

Ref. No.	Part No.	DESCRIPTION	QUANTITY	REMARKS
1	376/300	CARBURETTER, $\frac{1}{8}$ in. choke	1	T90
1	376/273	CARBURETTER, 1 in. choke	1	T100
2	376/001	Mixing chamber, $\frac{1}{8}$ in. choke	1	T90
2	376/002	Mixing chamber, 1 in. choke	1	T100
3	376/055	Jet block, $\frac{1}{8}$ in. choke	1	T90
3	376/056	Jet block, 1 in. choke	1	T100
4	376/067	Joint washer	1	
5	376/070	Peg screw	1	
6	376/158	Mixing chamber top	1	
7	376/197	Air valve	1	
8	376/402	Control rod and lever	1	
9	376/109	Return spring	1	
10	376/409	Friction washer	1	
11	30/064	Click spring	1	
12	376/065	Mixing chamber cap	1	
13	29/308	Spring	1	
14	4/241	Screw	1	
15	376/060	Throttle valve (3 cutaway)	1	T90
15	376/060	Throttle valve ($3\frac{1}{2}$ cutaway)	1	T100
16	376/061	Throttle return spring	1	
17	376/063	Needle (Type C)	1	
18	4/230	Needle clip	1	
19	376/072	Needle jet (.106)	1	
20	376/100	Main jet (180)	1	T90
20	376/100	Main jet (190)	1	See Pages 9 to 12
21	376/073	Jet holder	1	
22	376/074	Fibre washer	1	
23	376/075	Cover nut	1	
24	376/076	Pilot jet (20)	1	T90
24	376/076	Pilot jet (25)	1	T100
25	116/162	Fibre washer	1	
26	376/095	Cover nut	1	
27	332/017	Air adjusting screw	1	
28	4/148	Spring	1	
29	376/068	Throttle stop screw	1	
30	376/069	Spring	1	
31	376/085	Float spindle	1	
32	376/083	Float	1	
33	376/094	Bush	1	
34	376/078	Joint washer	1	
35	376/077	Cover	1	
36	376/079	Screw	3	
37	376/088	Needle seating	1	
38	376/089	Needle	1	
39	376/093	Filter	1	
40	376/091	Bolt	1	
41	376/092	Fibre washer	1	
42	376/086	Tickler	1	
43	376/087	Spring	1	
44	343/011	Tickler body	1	
45	244/1048	"O" ring seal... ..	1	
46	F4308	Petrol pipe	1	
47	376/066	Air intake tube	A	

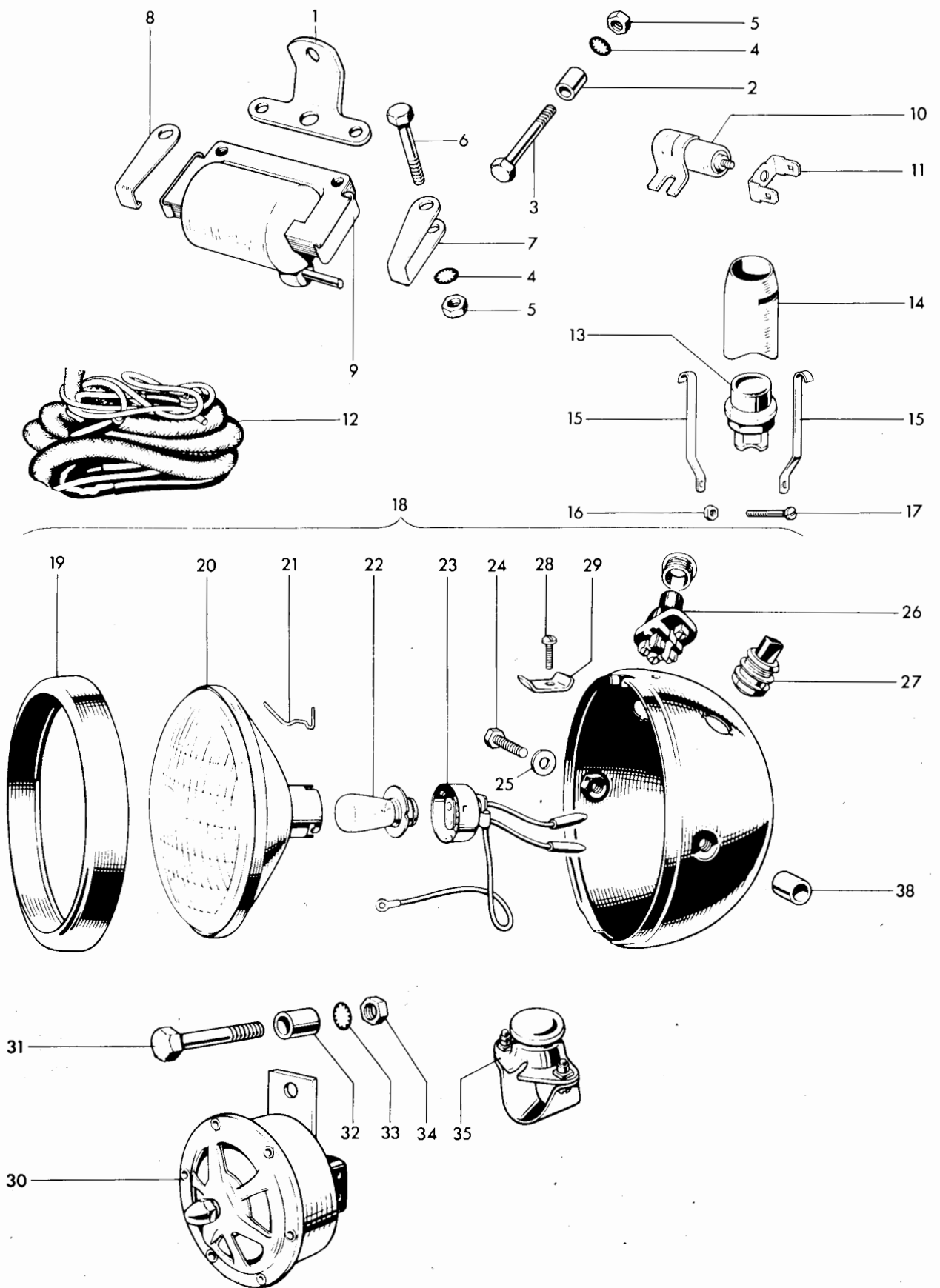

Fig. 32. A.C. MAGNETO IGNITION COILS, WIRING HARNESS AND DIRECT LIGHTING

A.C. MAGNETO IGNITION COILS, WIRING HARNESS AND DIRECT LIGHTING

Ref. No.	Part No.	Description	Quantity	Remarks
1	F6112	Coil bracket	4	
2	F4366	Distance piece	2	
3	F6122	Bolt (1 $\frac{3}{8}$ in. U.H.)	2	
4	E1612	Serrated washer	6	
5	F879	Nut	6	
6	W932	Bolt (1 in. U.H.)	4	
7	F6125	Retainer	2	
8	F6136	Retainer	2	
9	45149	Ignition coil, type 3ET	2	
10	54441582	Condenser	2	
11	54190108	Lucar terminal	2	
12	54937097	Wiring harness	1	
13	31071	Cut-out button, type SS5	1	"Kill button"
14	H1669	Cup	1	
15	H1670	Clip	2	
16	H687	Bolt ($\frac{3}{8}$ in. U.H.)	1	
17	H745	Nut	1	
18	58395	HEADLAMP ASSEMBLY, MCH 66	1	
19	534343	Rim	1	
20	54520452	Light unit	1	
21	504665	Fixing wire... ..	6	
22	166	Bulb (24/24W. Pre-focus, Vertical Dip)	1	
23	554602	Adaptor	2	
24	112201	Bolt	2	
25	137499	Washer	2	
26	31356	Lighting switch	1	
27	31620	Dip switch	1	
28	144921	Screw	1	
29	534296	Plate	1	
30	D552	Horn, clear hooters AC5855G	1	
31	11104/06/2	Bolt	1	
32	F4366	Distance piece	1	
33	E1612	Serrated washer	1	
34	15104/00/2	Nut	1	
35	D553	Horn push, clear hooters No. 10	1	
36	53972	STOP AND TAIL LAMP, Type 679	1	Except for bulb
37	384	Bulb (6/18 W. Offset pin)	1	See Page 87
38	F3069	Distance piece	2	

36 and 37 not illustrated.

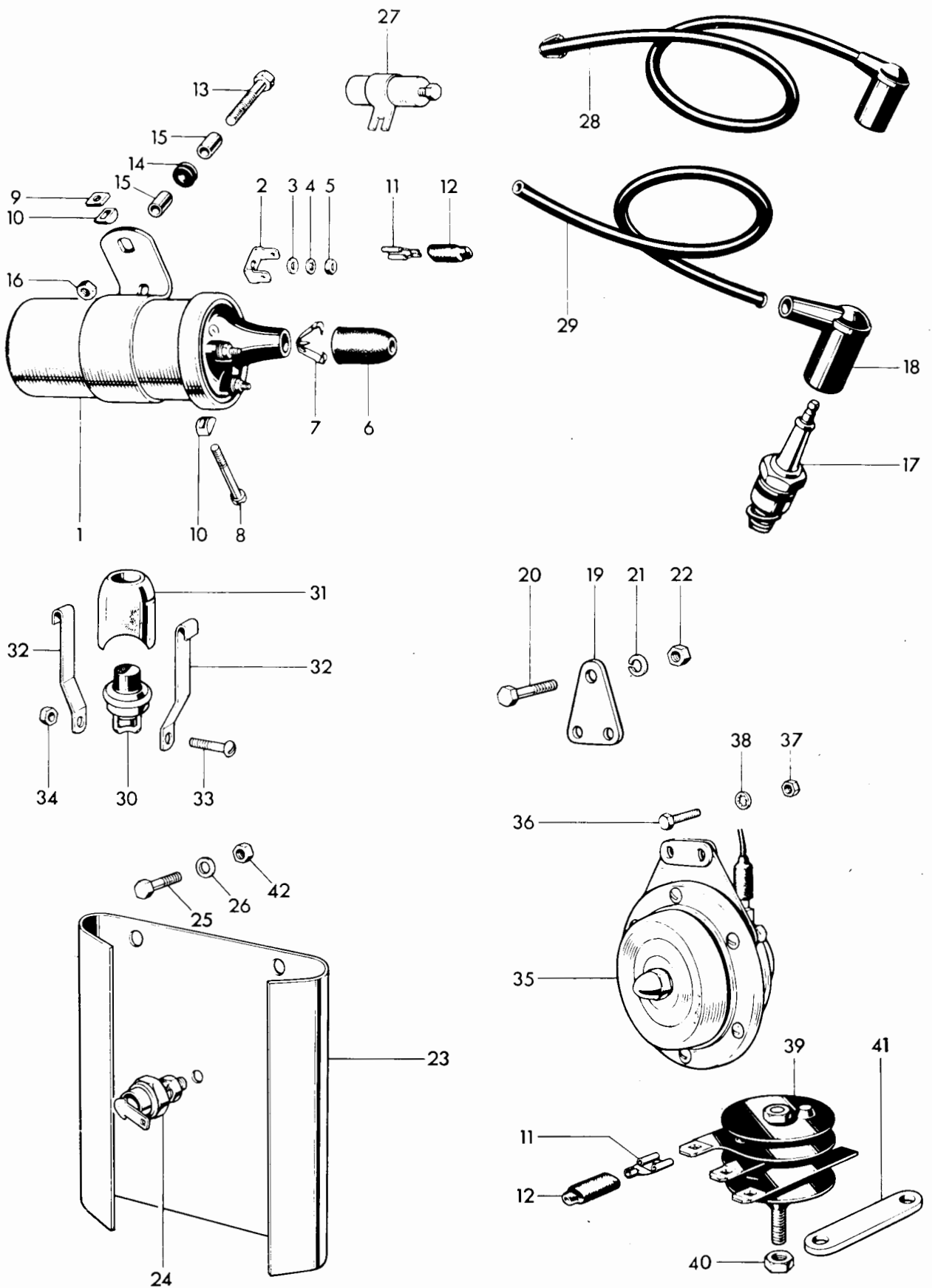

Fig. 33. D.C. IGNITION COILS, HORN, RECTIFIER AND ZENER DIODE

D.C. IGNITION COILS, HORN, RECTIFIER AND ZENER DIODE

Ref. No.	Part No.	DESCRIPTION	QUANTITY	REMARKS
1	45110	IGNITION COIL. Type MA12	2	
2	54190108	Lucar terminal	4	
3	131023	Plain washer (E2351)	4	
4	188330	Serrated washer (GS299)...	4	
5	166043	Nut (F3799)	4	
6	421554	Rubber grommet	2	
7	421863	Cable clip	2	
8	100104	Screw	2	
9	169160	Square nut	2	
10	422369	"D" washer	4	
11	54942078	Lucar connector	as required	
12	54190042	Insulating cover...	as required	
13	F3809	Bolt ($1\frac{3}{4}$ in. U.H.)	2	
14	F5466	Rubber grommet	2	
15	F5467	Distance piece	4	
16	E3290	Self locking nut	2	
17	—	Sparking plug (Champion N4)	2	
18	D262	Plug cover	2	U.S.A.
19	F6632	Horn bracket	1	
20	H426	Bolt ($\frac{3}{32}$ in. U.H.)	1	
21	S26-1	Spring washer	1	
22	S1-52	Nut	1	
23	F6900	Mounting plate	1	
24	49345	Zener diode	1	
25	DS57	Bolt ($\frac{7}{16}$ in. U.H.)	2	
26	S25-1	Washer	2	
27	54441582	Condenser	2	U.S.A.
28	54937976	H.T. lead complete (resistive)	2	
29	842183	H.T. lead (7 m.m. cable)	2	U.S.A.
30	35601	Cut-out button, type SS5	1	"Kill button"
31	H1669	Cup	1	
32	H1670	Clip	2	
33	H687	Bolt ($\frac{3}{8}$ in. U.H.)	1	
34	H745	Nut	1	
35	70164	Horn, type 8H	1	
36	F4771	Screw ($\frac{3}{8}$ in. U.H.)	2	
37	F3799	Nut	2	
38	GS299	Serrated washer	2	
39	49072	Rectifier, type 2DS 506	1	
40	F5338	Nut (156 596)	1	
41	F6896	Bracket	1	
42	F879	Nut	2	

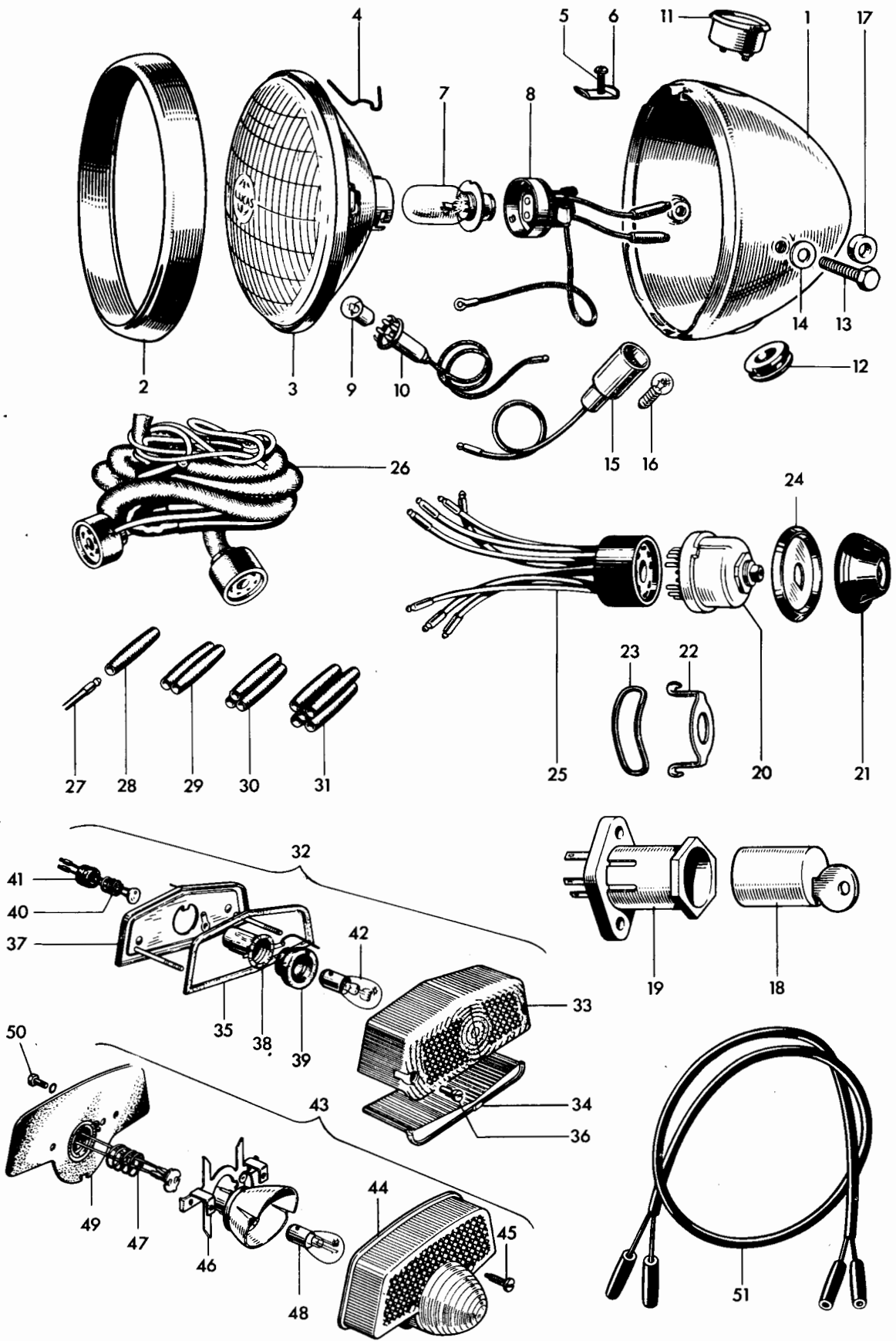

Fig. 34. HEADLAMP, WIRING HARNESS, SWITCHES AND TAIL LAMP

HEADLAMP, WIRING HARNESS, SWITCHES AND TAIL LAMP

Ref. No.	Part No.	DESCRIPTION	QUANTITY	REMARKS
1	59579	HEADLAMP COMPLETE	1	
2	553248	Rim ...	1	
3	516798	Light unit ...	1	
4	504665	Fixing wire...	6	
5	144921	Screw ...	1	
6	534296	Plate ...	1	
7	446	Bulb (50/40 W. Vert dip. Pre-focus)	1	
8	554602	Main bulbholder	1	
9	988	Bulb (3W. M.C.C.)	1	
10	554710	Pilot bulbholder ...	1	
11	36296	Ammeter type 2AR	1	
12	862217	Grommet ...	1	
13	112201	Bolt ...	2	
14	137499	Plain washer ...	2	
15	38189	Ignition warning light body	1	
16	281	Bulb (2W. BA7S)	1	
17	H1932	Headlamp spacer	2	
18	F6981	Ignition lock c/w two keys	1	
19	31899	Ignition switch, type S45	1	
20	34289	Lighting switch, type 88SA	1	
21	54330934	Knob c/w screw	1	
22	F5983	Bracket ...	1	
23	F5988	Rubber band ...	1	
24	54330576	Switch bezel plate	1	
25	54930007	Replacement harness socket (Lighting)	1	
26	54938941	Wiring harness ...	1	
27	900269	Snap connector terminal		as required
28	900288	Single snap connector		as required
29	850641	Double snap connector		as required
30	850844	Triple snap connector		as required
31	850832	Quintuple snap connector		as required
32	53454	STOP AND TAIL LAMP, Type 564	1	} 3TA, 5TA T90, T100
33	573839	Lens ...	1	
34	575200	Window ...	1	
35	575208	Lens seating gasket	1	
36	575219	Sleeve nut ...	2	
37	576002	Base assembly ...	1	
38	575209	Bulbholder ...	1	
39	575207	Grommet ...	1	
40	573828	Contact assembly ...	1	
41	573625	Grommet ...	1	
42	380	Bulb (6/21 W. Offset pin)	1	
43	53973	STOP AND TAIL LAMP, Type L679	1	} T100R
44	54572932	Lens...	1	
45	572289	Screw ...	2	
46	54574348	Bulb holder with reflector	1	
47	573828	Contact assembly ...	1	
48	380	Bulb (6/21 W. Offset pin)	1	
49	54571677	Gasket ...	1	
50	127684	Screw ...	2	
51	838604	Stop and tail lamp lead	1	

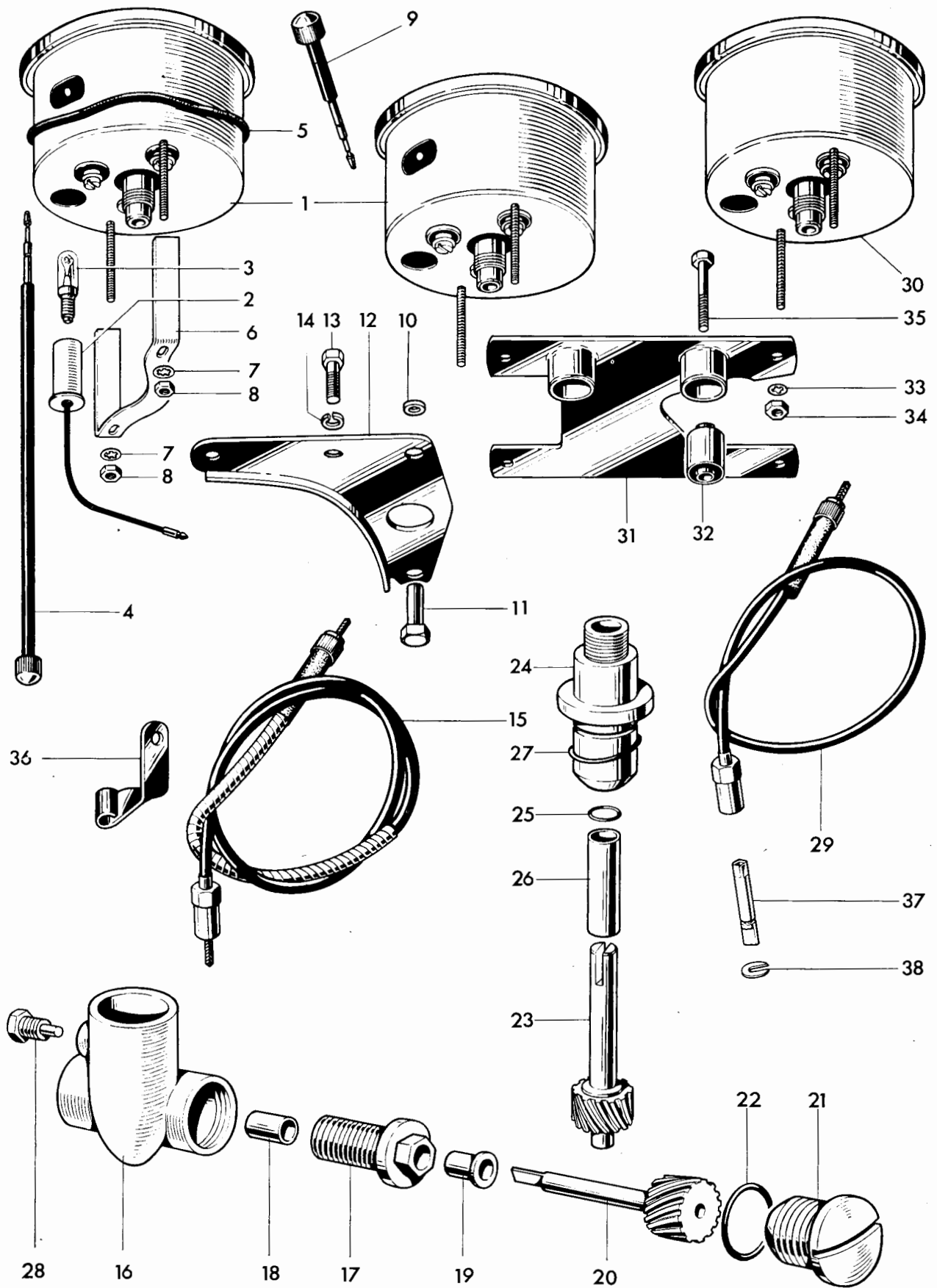

Fig. 35. SPEEDOMETER AND TACHOMETER

SPEEDOMETER AND TACHOMETER

Ref. No.	Part No.	DESCRIPTION	QUANTITY	REMARKS
1	SSM5002/00	Speedometer head MPH	1	3TA, 5TA
1	SSM5002/01	Speedometer head KPH	1	Alternative 3TA, 5TA
1	SSM5001/00	Speedometer head MPH	1	T90, T100
1	SSM5001/01	Speedometer head KPH	1	Alternative T90,T100
2	554734	Bulb holder	1	
3	987	Bulb, 3.W. M.E.S.	1	
4	41-118-127-72	Trip control	1	} 3TA, 5TA
5	31-753-778	Rubber ring	1	
6	31-674-188-01	Fixing strap	1	
7	30-283-014-11	Washer	2	
8	30-277-023-11	Nut	2	
9	41-148-203-10	Trip control	1	} T90, T100
10	H1702	Distance piece	2	
11	H1701	Sleeve nut	2	
12	H1668	Bracket	1	
13	DS57	Bolt ($\frac{7}{8}$ in. U.H.)	2	
14	S26-2	Spring washer	2	
15	D609	Speedometer cable (65 ins. long)	1	Smiths DF9110/00
16	E5755	TACHOMETER GEARBOX	1	} T100R
17	E5153	Securing screw	1	
18	E5156	Bush	1	
19	E5155	Flanged bush	1	
20	E5157	Driving gear	1	
21	E5759	End cap	1	
22	E6300	"O" ring	1	
23	E5578	Driven gear	1	
24	E6122	Driven gear housing	1	
25	E6299	"O" ring	1	
26	E6124	Bush	1	
27	E3309	"O" ring	1	
28	E5881	Set screw	1	
29	D578	Tachometer cable (28 in. long)	1	
30	RSM3003/01	Tachometer	1	
31	H1946	MOUNTING BRACKET	1	
32	H1929	Metallastik Bush	2	
33	30-282-014-11	Washer	2	
34	30-276-037-11	Nut	2	
35	H1086	Bolt ($1\frac{3}{8}$ in. U.H.)	2	
36	H1698	Cable bracket	1	
37	D493	Spade	1	
38	D494	Circlip	1	